

WMC (Magnetic Bearing) Centrifugal Chiller

Service and Repair Course



Schedule for 2012

February 7 – 10, 2012
September 18 – 21, 2012

WMC Centrifugal Chiller
Service & Repair Course is
held at:

McQuay International
Staunton, VA

Daikin McQuay Learning Institute
P.O. Box 2510
Staunton, Virginia 24402-2510
Phone: (540) 248-9646
Fax: (763) 509-7663

Visit Our Web Site at:
www.mcquay.com
for the latest training
schedules

McQuay International has
been approved as an
Authorized Provider by the
International Association for
Continuing Education and
Training (IACET),
1760 Old Meadow Road,
Suite 500, McLean, VA 22102;
(703) 506-3275



WMC (Water-Cooled Magnetic Bearing) Training

This brochure lists the dates for the WMC (Water-Cooled Magnetic Bearing) Centrifugal Chiller **Service & Repair** training program. This training course is designed to teach the maintenance and service technician how to maintain, operate, troubleshoot, and repair McQuay WMC Centrifugal chillers.

The program is structured to provide basic classroom instruction to familiarize the student with the features, maintenance, service and repair of McQuay WMC Centrifugal chillers. Hands on exercises for troubleshooting, repair and replacement of key compressor components is included in the class.

All scheduled sessions are held in our newly remodeled Training Center at our manufacturing facility in Staunton, Virginia.



WMC CENTRIFUGAL CHILLER CONTROL TRAINING INCLUDES THE MICROTECH II® CONTROL SYSTEM.

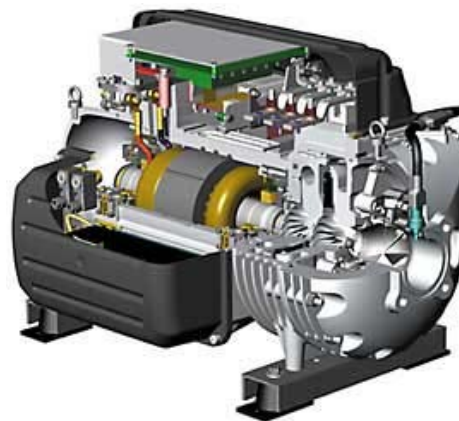

Course Fee:
\$2,500.00

Per student payable to
McQuay International

Fee Includes:

All instruction and work materials including compressor service manual, compressor service monitoring software and DC buss test harness
Daily lunches and coffee breaks
Group Dinner (first night)

Payment is due in advance.

Application accompanied by payment should be submitted to:

Daikin McQuay Learning Institute
Linda Custer
P.O. Box 2510
Staunton, VA 24402-2510

If other payment arrangements are necessary, direct all inquiries to:

Linda Custer
Training Administrator
Phone: (540) 248-9646
Fax: (763) 509-7663

e-mail:
linda.custer@mcquay.com

***Specifically Designed
for
Servicing Contractors
and
Maintenance Personnel***

Learning Outcomes:

Prerequisite:

The student should have a minimum of 5 years experience with Centrifugal chillers to maximize the benefit of this course. The WMC chiller uses a centrifugal compressor that has highly technical components.

In this course, students will learn:

- The basic refrigeration cycle of water chillers
- Centrifugal compressor theory
- WMC Compressor design and operation
- Compressor sequencing, MicroTech® II for WMC software & programming
- MicroTech® II interface for WMC chillers
- Electronic EXP valve operation
- WMC compressor troubleshooting and repair procedures
- WMC compressor monitor software program
- System performance evaluation
- The class includes product review, plant tour of manufacturing facility and group hands-on training on MicroTech® II simulators

Assessment:

At the conclusion of the course, the student will review, discuss and be assessed with a test on the learning outcomes of the course. The test will be graded based on the percentage of questions to determine the students' learning outcome. A score of 70% will be required for successful completion of the course and to be awarded CEU's (continuing education units).

Enrollment/Payment:

Enrollment is limited and will be accepted on a first-come, first-serve basis. To enroll, please register online at www.mcquay.com, on the Training Page or fill out the attached enrollment form. Confirmation of enrollment along with an information packet will be sent to the student within five working days after receipt of your paid application. Full payment is required in advance of the class. If payment is not received prior to the start of class, the student(s) will be denied entrance.

Cancellation Policy:

For Cancellations made within 10 working days prior to course start date, the enrollee(s) will be charged the full course fee. Cancellations made less than four weeks prior to the course start date will be charged 50% of the course fee. An alternative person may use a confirmed space without penalty and substitutions may be made up until start of class.

Motel:

A list of area motels will be provided with McQuay preferred rates.

Transportation:

Students are responsible for their own transportation to and from the training center.

Attire: Dress is business casual. Students are required to wear steel toe shoes during the plant tour, at all times when passing through the production areas to and from the cafeteria through the plant. Safety glasses will be supplied.

WMC Centrifugal Chiller Service & Repair Course Application

(One application per student)

Company Name: _____

Mailing Address: _____

Student Name(s): _____ Nickname: _____

Phone Number: _____ Fax Number: _____

E-Mail Address: _____

PLEASE SPECIFY PAYMENT METHOD BELOW. ~~ PAYMENT IS REQUIRED IN ADVANCE ~~

CREDIT CARD Master Card VISA American Express Discover (Novus)

Card Number: _____

Expiration Date: ____ / ____ / ____

Cardholder Printed Name: _____

Cardholder Signature: _____

PURCHASE ORDER

(copy of PO MUST accompany registration)

CHECK

Checks MUST be received 30 days prior to start of class.

Tuition is **\$2,500.00** for 3 1/2 days. If fee is enclosed with application confirmation will be prompt.

Fax application, copy of purchase order/check to:
(763) 509-7663

Mail copy of application form and check to:

Daikin McQuay Learning Institute
Attn: Linda Custer
PO Box 2510
Staunton, VA 24402-2510

APPLICATION AND PAYMENT SHOULD BE MAILED 60 DAYS PRIOR TO CLASS DATE.
PAYMENT IS DUE IN ADVANCE OR STUDENT(S) WILL NOT BE ADMITTED.

2012 COURSES – CHECK COURSE SCHEDULE DESIRED:

February 7 -10, 2012

September 18 – 21, 2012

Classes are held at our manufacturing and training facility in Staunton, Virginia

How were you referred to the McQuay Training Program?

Sales/Service Representative (name) _____ Magazine Website
 Training Catalog/Brochure Attended previous McQuay course Other _____

McQuay International reserves the right to make changes or alterations to the course content or schedule. McQuay International is not responsible for fees associated with changing dates or cancellation of classes. In the unlikely event of a schedule change or cancellation, every effort will be made to notify all registrants in a timely manner.