



**Catalog 865-5**

## **Modular Self-Contained Air Conditioning Systems**

**Type SWT 023C—040C**  
**20 to 45 Tons**



*Engineered for flexibility and performance™*

<b>Continued Leadership in Floor-By-Floor, Self-Contained System Designs</b> .....	<b>3</b>	<b>Application Considerations</b> .....	<b>18</b>
Nomenclature .....	3	General .....	18
Agency Listed .....	3	Unit Location .....	18
System Performance Providing Tenant Comfort and Operating Economy .....	4	Acoustical Considerations .....	19
<b>McQuay Self-Contained VAV Systems</b> .....	<b>4</b>	Recommended Clearances .....	19
Cabinet, Casing and Frame .....	5	Equipment Room .....	19
Modular Design .....	5	Ductwork .....	19
Condensing Section .....	5	Vibration Isolation .....	20
<b>Design Features</b> .....	<b>5</b>	Condenser Water Piping .....	20
Cooling Coil Section .....	6	Head Pressure Control .....	20
Heating Section .....	6	Variable Air Volume .....	20
Supply Fan Section .....	6	Variable Frequency Drives .....	20
Economizer Options .....	7	Duct Static Pressure Sensor Placement .....	20
Filter Section .....	7	Zone Sensor Placement .....	20
Electrical .....	8	Filtration .....	21
Controls .....	8	System Operating Limits .....	21
Auxiliary Control Options .....	8	Coil Freeze Protection .....	22
Selection/Application Flexibility .....	9	Air Density Correction .....	22
Modular Construction .....	9	Unit Wiring .....	22
<b>System Flexibility</b> .....	<b>9</b>	<b>Application Considerations</b> .....	<b>22</b>
Controllers .....	10	<b>Selection Procedure</b> .....	<b>23</b>
Ultraviolet Lights .....	10	<b>Physical Data</b> .....	<b>25</b>
Refrigerant R-407C .....	10	Unit Efficiency Ratings .....	26
<b>MicroTech® III Unit Controller</b> .....	<b>11</b>	Correction Multipliers .....	26
Open Choices Benefits for Easy Integration ....	11	DX Cooling Capacity Data .....	26
Alarm Management and Control .....	17	<b>Performance Data</b> .....	<b>26</b>
		Waterside Economizer Capacity .....	29
		Heating Capacity Data .....	31
		Component Pressure Drops .....	31
		Fan Curves .....	34
		<b>Dimensional Data</b> .....	<b>37</b>
		<b>Electrical Data</b> .....	<b>40</b>
		Supply Power Wiring .....	41
		<b>Unit Weights</b> .....	<b>42</b>
		<b>Engineering Guide Specifications</b> .....	<b>43</b>
		General .....	43
		Safety Agency Listed .....	43
		Cabinet, Casing and Frame .....	43
		Filter/Economizer Section .....	43
		Fan Section .....	44
		Coils .....	44
		Electrical .....	45
		MicroTech III Unit Controller .....	46
		Open Communications Protocol .....	48

# Continued Leadership in Floor-By-Floor, Self-Contained System Designs

McQuay SWT self-contained air conditioning systems trace their history to the late 1970s and the pioneering concepts of Blazer Industries. Working closely with the consulting engineer to solve special system and space challenges, Blazer Industries developed and provided the first self-contained, variable air volume systems with water side economizer cycle for the prestigious 499 Park Avenue office building. Following the success of this project was more than a decade of innovation and product leadership, with thousands of systems provided for prominent building projects.

In 1991, McQuay acquired Blazer Industries. The result has been a continuation of this tradition of innovation and leadership. The comprehensive, updated modular McQuay SWT system offering is now supplying quiet, efficient and flexible systems to meet today's diverse and demanding performance needs for new and retrofit, commercial, industrial and institutional buildings worldwide.

## Nomenclature

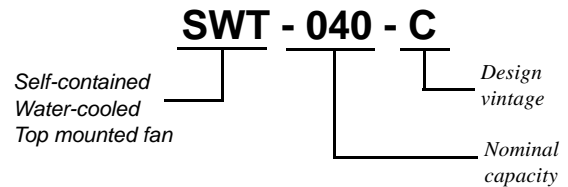

## Agency Listed



McQuay and MicroTech are registered trademarks of McQuay International.  
DesignFlow, Hi-F, Protocol Selectability, RoofPak, SelectTools, SpeedTrol, SuperMod, UltraSeal, and VaneTrol are trademarks of McQuay International.

Microsoft is a registered trademark of Microsoft Corporation.

Windows is a trademark of Microsoft Corporation.

Copyright © 2011 McQuay International. All rights reserved throughout the world.

# McQuay Self-Contained VAV Systems

## System Performance Providing Tenant Comfort and Operating Economy

Since the introduction of self-contained systems in the late 1970s, the industry has seen this concept grow into one of the most widely specified systems for new office buildings, for retrofitting existing structures, and for institutional, industrial, and other specialized applications. The reason is simple: system performance. Designed specifically to satisfy growing system retrofit needs, McQuay SWT self-contained VAV systems provide the total performance advantage of:

- Modular construction
  - Prime candidate for building renovation
  - Special 34.5" maximum section width fits through a 3' door frame
  - Refrigerant lines always remain intact
  - Requires minimum floor area when reassembled
  - Retrofit alternative where existing chiller cannot be accessed for replacement
- Tenant Comfort
  - Tenants enjoy individual control over comfort conditions and off-hour system operation
  - Tenants benefit from their individual efforts to control energy costs
  - Routine service is located where it minimizes tenant inconvenience
  - Individual or dual systems per floor provide system redundancy and standby
- First cost economics
  - VAV system flexibility uses building diversity to reduce system tonnage and first cost
  - Factory packaged concept reduces field labor, installation time and expense
  - No expensive chilled water piping or chiller room
  - Individually tested, factory designed systems reduce start-up and installation expense
  - Reduce penthouse and equipment room requirements
  - Centralize condenser water and condensate piping and streamline system layout
- Energy-saving VAV system control
  - Reduces fan kW and operating costs at part load conditions
  - Savings maximized through use of variable speed fan control
  - Individual zone control without overcooling or use of reheat
- Quiet system operation
  - Provided by structural quality and specialized design
  - Recognized for quiet operation by renowned U.S. acoustical consultants
- Energy saving economizer operation
  - Water or air economizer capability for optimized energy savings
  - Economizer reduces compressor operating hours and energy costs
  - Year-round "free cooling" capability

- Energy saving building part load operation
  - System energy efficiency comparable to central chilled water systems
  - Multiple systems and compressors versus a single, large central plant
  - Efficient system for partial occupancy and after hours operation
  - Operate only the system(s) on the floor(s) requiring after hours use

Figure 1. McQuay Self-Contained VAV Systems

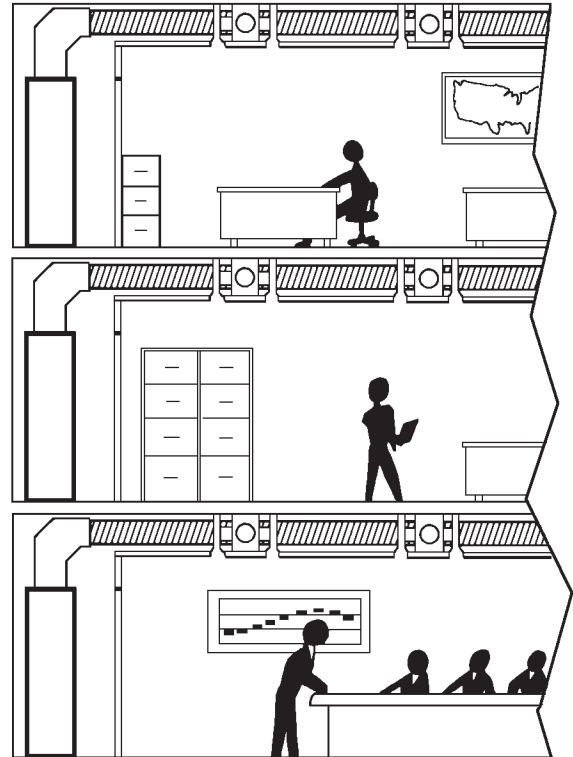

- System savings of advanced MicroTech III™ DDC control system
  - Monitoring and diagnostics reduce the potential for expensive field repairs
  - Industry leading Protocol Selectability™ feature provides effective BAS selection flexibility
- Reduced system maintenance and service costs
  - No complicated central chiller plant to maintain
  - Service and maintenance are performed out of the occupied space
  - Control and product reliability functions designed by the equipment manufacturer for single source responsibility and improved reliability

## Cabinet, Casing and Frame

For vibration control and rigging strength, the SWT unit base is constructed of welded structural steel channel and 10-gauge galvanized steel panels. Heavy-duty lifting brackets are strategically placed for balanced cable or chain hook lifting.

For long equipment life, unit exterior panels are constructed of heavy gauge, pre-painted, galvanized steel. The complete cabinet, frame and access panels are insulated with 1 inch thick, 1.5 lb. dual density insulation. Double wall construction is available to enhance performance and satisfy IAQ requirements.

For maintenance and service ease, system components are strategically located for ease of inspection and maintenance. Refrigeration components are positioned out of the airstream so adjustments and readings can be made without disrupting system operation. Service friendly access is made through heavy-duty, conveniently removable panels. Access panels are set on neoprene gaskets to prevent air leakage.

## Modular Design

The SWT unit is easily disassembled into three compact sections; main cooling/heating, filter/waterside economizer and fan. See "Modular Construction" under "System Flexibility" on page 9.

Figure 2. SWT Cabinet



## Condensing Section

Multiple compressors are featured in all SWT systems for efficient system part load control, quiet operation and system redundancy. Compressors are quiet, reliable hermetic scroll type complete with sightglass, anti-slug protection, and motor overload protection. Suction and discharge service valves, with gauge ports, are available on each compressor. Individual branch circuit fusing protects each compressor. The unit's MicroTech III™ control system incorporates timing functions to prevent compressor short cycling. All compressors are resiliently mounted to minimize any noise transmission. The condensing section is insulated and segregated from the air handling section of the unit to avoid transmission of noise to the circulated air stream.

Figure 3. Copeland Specter™ scroll compressor



Each compressor is on an independent refrigerant circuit complete with filter-drier, liquid moisture indicator/sightglass, thermal expansion valve capable of modulation from 100-25% of its rated capacity, liquid line shutoff valve with charging port, high pressure relief device and high and low pressure cutouts. If any compressor is made inoperable, the remaining compressors are still allowed to operate.

The unit's MicroTech III controller senses entering condenser water temperature and prevents mechanical cooling when the temperature falls below an adjustable setpoint value, minimum 55°F. For systems which will see entering condenser water temperatures below 55°F, a waterside economizer or head pressure activated control valve is available.

SWT water cooled condensers feature a mechanically cleanable, all copper design using the same high performance enhanced tubing found in modern centrifugal chillers. Liquid refrigerant sub-cooling is provided as standard. Each condenser is part of an independent refrigerant circuit and comes complete with a spring loaded high pressure relief valve. All condensers are independently leak tested. All completed units are leak tested, evacuated and shipped with a full operating charge of R-22 and oil. R-407C is also available as an alternate selection.

The condenser assembly and all factory water piping is rated for a waterside working pressure of 400 psig and is factory leak tested before shipment. Condenser water channels are mechanically cleanable by removing brass service plugs that are sealed with

# Design Features

reusable o-ring gaskets. Main interconnecting condenser water headers include vent and drain plugs and a large cleanout plug for removing debris dislodged during cleaning. Condensers are factory piped for a single condenser water supply and a single condenser water return connection.

Both right-hand and left-hand piping locations are available.

## Cooling Coil Section

SWT evaporator coils incorporate a high efficiency ripple corrugated fin design. SWT system design maximizes coil face area without developing uneven, performance robbing disruptions in airflow patterns. The result is high coil performance and reduced static pressure losses. Coils are 4 or 6 row configurations.

The evaporator coil is mounted in a stainless steel double sloped drain pan. The condensate drain line is trapped internal to the unit, eliminating the expense and inconsistency of field installed traps.

Figure 4. Evaporator Coil Circuiting

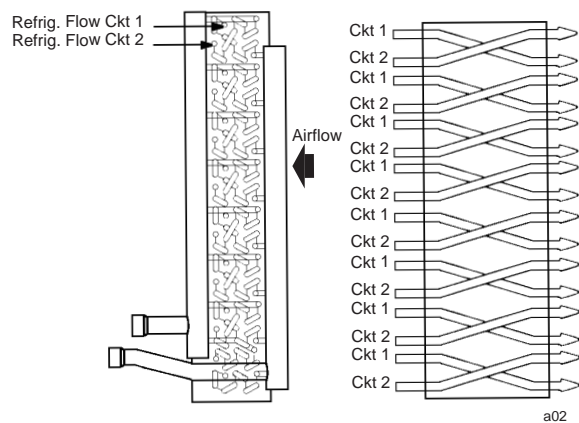

All evaporator coils are interlaced circuiting, keeping the full face of the coil active to eliminate air temperature stratification. For optimum part load performance, all three and four circuit evaporator coils are circuitured for both interlaced and row control. Compressor staging is sequenced to take maximum advantage of available coil surface.

Each evaporator coil circuit is furnished with a wide range thermostatic expansion valve with an adjustable superheat setting and external equalizer.

## Heating Section

SWT units are available as cooling only systems or with factory installed electric or hot water heat for morning warm-up, constant volume and specialty heating requirements.

### Electric Heat

The factory assembled electric heating coils are constructed of low watt density nickel-chromium elements for long lasting durability. Electric heaters are protected by automatic reset high limit controls and line break protection. Heater branch circuits are individually protected by branch circuit fusing. The MicroTech III control system sequences the electric heating elements for operating economy.

## Hot Water Heat

Hot water coils have 1 or 2 rows with high efficiency ripple corrugated fin design and 1/2 inch O.D. seamless copper tubes. Coils are available complete with a factory mounted, piped and wired 2-way or modulating valve controlled by the unit's MicroTech III controller. A factory mounted freeze-stat is provided to help protect against coil freeze-up.

## Supply Fan Section

Figure 5. Supply Fan



The supply fan section uses one or two double width, double inlet medium pressure forward curved fans and housings. Each fan is statically and dynamically balanced. The fan assembly is constructed of high strength structural steel and welded for maximum strength. The entire fan assembly is mounted on spring isolators for excellent isolation effectiveness. Seismic control restrained spring isolators are available. A vibration dampening flex connection is installed at the fan discharge. The entire fan, motor and drive assembly is dynamically balanced at the factory for quiet operation.

Supply fans are configured with a gradual expansion, aerodynamic duct within the cabinet. This unique gradual expansion feature contributes to the high performance of the SWT by lowering brake horsepower and sound power levels.

All fans are mounted on solid steel shafts rotating in 200,000 hour pillow block ball bearings with grease fittings. Multiple belt, fixed pitch sheaves are matched to the specific cfm, static pressure and horsepower requirements of the system. Drives rated for a minimum of 150% of fan design are available. Drive components and fan bearings are easily accessed for periodic maintenance.

Fan motors are three phase, NEMA design B, rated at 40°C. Motor availability includes high efficiency open drip-proof and totally enclosed, EPACT compliant, NEMA T-frame selections and premium efficiency selections. Motors are 1800 RPM with grease lubricated ball bearings.

Energy saving advanced technology variable frequency drive (VFD) fan speed control is available with the convenience and cost savings of factory mounting and testing. All VFD selections are plenum rated. A manually activated bypass contactor is available to allow system operation even in the event of drive service. MicroTech III controls provide advanced duct static pressure control. Static pressure can be controlled by either a single or two duct static pressure sensors. All VAV systems include an adjustable duct high-limit switch to protect duct work from excessive pressure.

## Economizer Options

### Waterside Economizer

An energy saving, waterside economizer package is available on all units. The complete economizer system is factory mounted including a 4-row mechanically cleanable coil, control valves and factory piping complete with cleanouts. The complete economizer package is rated for up to 400 psig waterside working pressure and the entire coil and piping assembly is factory leak tested.

Economizer operation is controlled by the SWT's MicroTech III controller to maximize free cooling potential. Economizer operation is enabled whenever the available cooling tower water temperature is less than the unit entering air temperature by a field adjustable value, generally 5-7°F. The economizer control valve modulates in response to the cooling load. Control valve operation can be selected to (1) maintain full flow through the unit at all times or (2) isolate the unit from the condenser water loop when there is no call for cooling to save energy with a variable pumping system. (Economizer control valves do not eliminate the need to provide unit isolation valves.) To extend free cooling savings, mechanical cooling is enabled during economizer operation. Only when the economizer valve is driven 90% open and the cooling load is not satisfied, will compressors be staged to maintain cooling setpoint. Economizer control will maintain full free cooling capability until disabled by the economizer changeover setpoint. A factory mounted freeze-stat is provided to help protect against coil freeze-up.

### Airside Economizer

An airside economizer control package is available for controlling field installed mixing dampers capable of 100% outside airflow. Economizer operation will be controlled by the SWT's MicroTech III controller to maximize free cooling potential. Economizer operation is enabled whenever an outside air (or comparative) enthalpy sensor or outside air temperature sensor indicates that outside air is suitable for free cooling. The economizer damper control actuator shall modulate in response to the cooling load. The outside air damper will be positioned to maintain minimum ventilation requirements when economizer is disabled.

To extend free cooling savings, mechanical cooling is enabled during economizer operation. Only when the economizer damper is driven 90% open and the cooling load is not satisfied, will compressors be staged to maintain cooling setpoint. Economizer control will maintain full free cooling capability until disabled by the economizer changeover setpoint. Factory supplied mixing boxes are available for airside economizer use using the McQuay Vision™ air handling unit platform.

### Condenser Head Pressure Control

For applications where a waterside economizer package is not being used and entering condenser water temperatures can be less than 55°F, condenser head pressure control is required. To satisfy these applications, a factory installed 2-way, head pressure activated control valve is available to maintain unit operation with entering condenser water temperatures as low as 40°F.

*Figure 6. Mechanically Cleanable Waterside Economizer Coil*

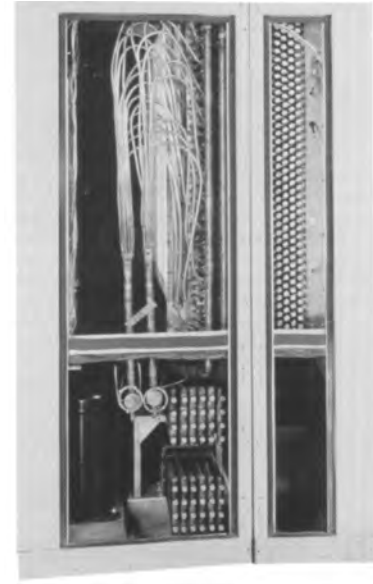

*Figure 7. Economizer Piping*



### Filter Section

All SWT units are provided, as standard, with 4" deep extended media 30% efficient filters. For higher filtration requirements, 65% and 85% AmericanAirFilter™ Varicel® filters are available with an optional pre-filter rack. Filters are removable from the rear of the unit or through hinged and latched side access doors on the filter box.

# Design Features

## Electrical

Each unit is completely wired and tested at the factory prior to shipment. Wiring complies with NEC requirements and conforms to all applicable UL standards for reliability and safety. All electrical components are labeled according to the electrical diagram and are UL recognized whenever applicable. Line voltage components and wiring are physically separated from the low voltage control system.

The supply fan motor, compressor motors and electric heat all have individual branch circuit fuse protection. Control circuit power is supplied through a factory installed, low voltage transformer. The supply fan motor circuit includes a three phase contactor and ambient compensated overload protection with manual reset. Each refrigerant circuit includes both a high and low pressure cutout switch and a coil frost protection thermostat.

A terminal block is provided for the single, main power connection and a terminal board is provided for low voltage control wiring. A factory mounted, non-fused main circuit interrupter is available for disconnecting the main electrical power to the unit. The switch is visible, located at the front of the unit, and is accessible without unit penetration. Dual power blocks or disconnect switches are available to accommodate requirements for standby, emergency power supplies.

## Controls

### MicroTech III Unit Controls

All SWT units feature advanced MicroTech III DDC controls to provide all temperature and static pressure control, product reliability control functions, system time clock and all monitoring and diagnostics. Each MicroTech III control system features a human interface with a 4-line, 20 character English language display for fast system diagnostics and adjustments. The complete control system is factory installed and commissioned prior to shipment.

### Protocol Selectability™ Feature

All MicroTech III control systems have McQuay's exclusive Protocol Selectability feature. MicroTech III control systems can be factory configured for standalone operation or for incorporation into an independent building automation system using either the BACnet® MS/TP, BACnet®/IP or LonTalk® protocols.

## Auxiliary Control Options

**Condenser Water Flow Switch** – A factory installed, flow switch is available to verify water flow status at each unit. Compressor operation is disabled and an alarm signal provided if condenser water flow is lost. Unit operation is restored when water flow has again been sensed. Water flow status is displayed at the MicroTech III control's plain language screen.

**Freezestat** – A nonaveraging type freezestat is available factory installed on the entering face of the economizer coil. Upon sensing a potential freeze condition, the unit supply air fan is shut down, the economizer (and heating) valve drives to the full open position and an alarm signal is provided. Unit operation is restored following the manual reset of the freezestat.

**Phase Failure/Undervoltage Protection** – Factory installed phase failure/under voltage protection is available to protect three phase motors from damage due to single phasing, phase reversal and low voltage conditions.

**Individual Unit Factory Test** – All SWT units are provided completely factory assembled, piped, wired, tested, and shipped in one piece. Each unit undergoes a factory test that includes:

- Dynamic trim balance of the completed fan assembly
- Run check of all electrical components, alarms and shutdowns, including proper control sequencing
- Pressure test, at rated pressure, of refrigerant coils, water coils and condensers prior to assembly
- Final leak check of the completed refrigerant circuits
- Final leak check of the completed water circuit
- Compressor run check

Verification of factory run test is available at time of unit shipment.

Figure 8. Test Stand

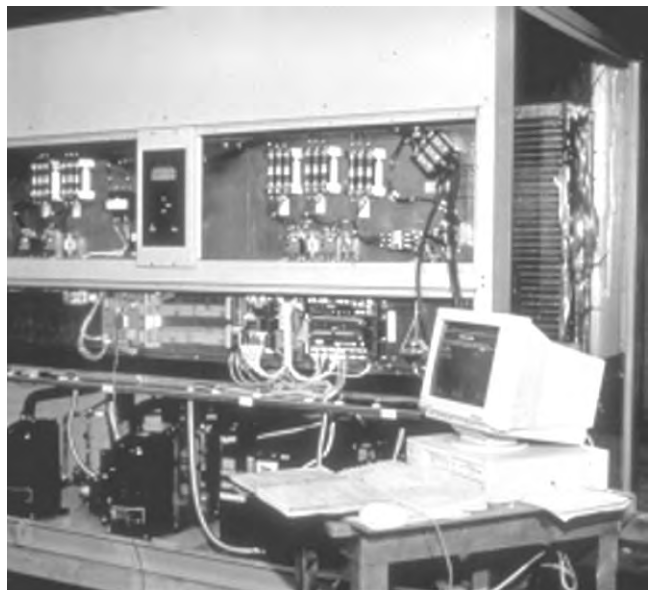

Along with providing high quality and state-of-the-art innovation, SWT self-contained systems emphasize system flexibility, flexibility not even considered by the competition. McQuay SWT systems offer customized flexibility to satisfy a wide range of diverse applications.

## Selection/Application Flexibility

Nominal cooling capacities range from 15 to 45 tons and all units feature a 6 row evaporator coil. In addition, all units offer multiple compressor selections to meet exacting system requirements. Many standard compressor/coil capacity selections are available. The flexibility to optimize the self-contained system to fit the application is a McQuay SWT advantage. Available system applications include:

- VAV discharge air temperature control with static pressure control
- Discharge air temperature control with constant air volume
- Constant volume, zone temperature control
- 100% outside air control
- Dehumidification control, with or without reheat control

In addition to compressor/coil flexibility, SWT systems offer double width, double inlet, forward curved fans with factory mounted variable frequency drives for maximizing VAV system fan performance. High efficiency fan capability coupled with extensive compressor flexibility can provide the right system selection for the application.

## Modular Construction

The SWT unit has been designed with the flexibility to be easily disassembled into three compact sections. The three sections are the main cooling/heating, filter/waterside economizer and fan sections. Whereas most competitive products require removal of the door frame, each SWT section has a maximum width of 34.5", including fastener heads, and can fit through standard 3' steel door frames.

The system installer is able to break the unit down into its three main sections without breaking any refrigerant lines. All SWT refrigerant lines remain intact, contained in the main cooling/heating section. This SWT feature can add up to substantial savings by avoiding the field expense to braze, evacuate and charge each refrigerant circuit.

### Optimal Discharge Air Temperature:

More and more system engineers are designing optimal discharge air temperature systems to improve system performance and system first cost, and the McQuay SWT provides the flexibility to do it successfully. Optimal discharge air temperature systems are designed to provide unit leaving air temperature selections of 52-53°F versus more conventional systems that supply air at temperatures closer to 58°F. This five to six °F reduction in air temperature to the room diffusers can subsequently reduce the required supply air volume to the room by 20-25%.

The benefits of optimal discharge air temperature systems become quite apparent with a look at the advantages offered with reduced air flow:

- Reduced supply air CFM reduces first cost and installation cost by allowing smaller duct sizes and a smaller air distribution system.
- Reduced supply air CFM reduces fan BHP requirements. Depending on changes in duct size and the resulting total static

pressure, a 20% reduction in supply air CFM can reduce the fan BHP requirements by 25% or more.

- Reduced supply air CFM provides reduced fan sound power generation and a quieter room environment.
- Reduced supply air CFM can often reduce the equipment room size due to the use of a physically smaller unit size.

Figure 9. Modular Construction

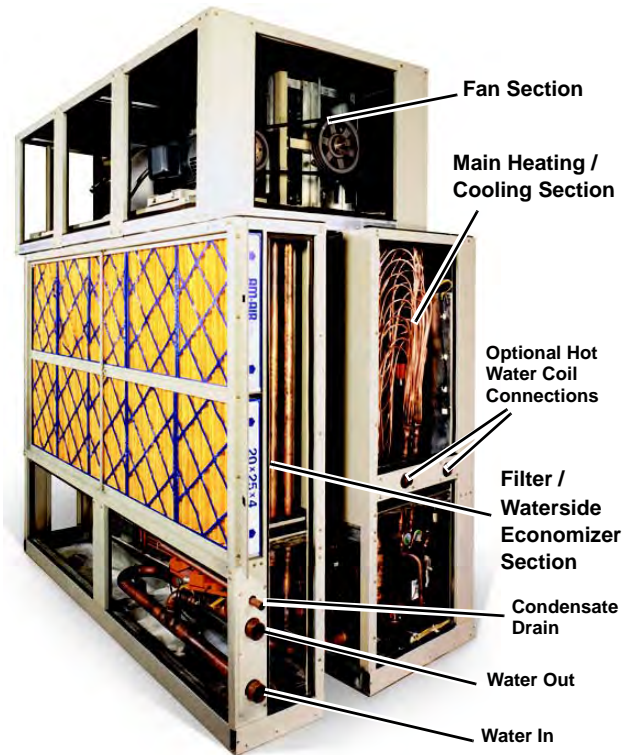

## Arrangement Flexibility

All SWT systems offer the flexibility of right-hand and left-hand piping arrangements and front and rear fan discharge orientations. Piping and fan arrangement flexibility can simplify mechanical equipment room arrangement, improve installed cost and improve total system performance.

## Filtration Flexibility

SWT systems are offered with 4 inch, 30% efficient pleated filters as standard. 4 inch, 65% efficient pleated filters and 4 inch, 85% efficient filters with pre-filters are also available.

## Energy Saving Economizer Flexibility

To improve system operating performance, all SWT systems offer complete factory mounted and controlled waterside economizer capability. Each waterside economizer system includes a 4 row, mechanically cleanable coil with dual, two-way control valves to allow use in either a constant or variable volume pumping system. In addition, units can be applied with air economizer cycles with integrated factory control.

## Heating Flexibility

A variety of heating media is offered with each SWT system. Hot water coils with modulating valve and actuator are available along with staged electric heat to provide heating control in a variety of applications.

# System Flexibility

## Controllers

MicroTech III DDC control systems provide constant volume, variable air volume, 100% outside air, and/or dehumidification control flexibility. Each MicroTech III control system comes with a control screen conveniently mounted on the front of the unit to allow easy adjustment and monitoring of control functions. And with its easy to follow and read English language menus and data displays, it simply encourages and invites the operator to take advantage of its many capabilities.

Figure 10. MicroTech III Controller



## Protocol Selectability Feature

All MicroTech III control systems have McQuay's exclusive Protocol Selectability feature. MicroTech III control systems can be factory configured for standalone operation or for incorporation into an independent building automation system using either the BACnet<sup>®</sup> MS/TP, BACnet<sup>®</sup>/IP or LonTalk<sup>®</sup> protocols.

## Summary of Available Options:

- Multiple compressor/coil capacity selections
- Multiple control options: VAV, CV, 100% OA, dehumidification
- Non-fused main power disconnect switch
- Dual non-fused main disconnect switches
- Non-averaging freeze-stat for hot water, or waterside economizer coil protection
- Unit phase failure/under voltage protection
- Premium efficiency fan motors
- TEFC fan motors
- Condenser water flow switch
- 4-row waterside economizer system
- Air cycle economizer system
- Modulating hot water heat
- Staged electric heat
- Factory mounted and controlled variable frequency drives
- High efficiency filtration options
- Right- and left-hand piping selections
- Front and back fan discharge arrangements
- Head pressure control valve
- Special coil coatings
- Double wall cabinet construction
- Seismic fan isolation
- R407C refrigerant
- UV lights

## Ultraviolet Lights

Factory-installed ultraviolet lights are available on the downstream side of all cooling coils and above the unit drain pan.

All ultraviolet lights are pre-engineered and factory installed for ease of use and proper placement for maximum effectiveness. The ultraviolet lamps irradiate the coil and drain pan surfaces with light in the 245 nanometer wavelength of the light spectrum (UV-C). UV-C light has proven effective in killing most bacteria, molds, and viruses in both laboratory and practical application. This complete package of equipment and ultraviolet lights includes Intertek Services Inc. (ETL) safety agency certification.

Figure 11: Ultraviolet light



## Features

- High-output, hot cathode lamps produce ultraviolet germicidal irradiation (UVGI) for 254 nm that constantly irradiates the coil and drain pan surfaces.
- Fixture design and stainless steel construction make the ultraviolet light device suitable for saturated air conditions.
- Automatic disconnects are standard on all doors (or panels) with line-of-sight access to the lamps to help prevent eye contact with the UV-C ultraviolet light.
- Special ultraviolet filtering glass windows block ultraviolet light, allowing the coil, drain pan, and lights to be inspected while in use from outside the unit.

## Benefits

- For pennies a day, UVGI can improve IAQ by destroying mold, fungi, and bacteria on coil and drain pan surfaces.
- Clean coil surfaces maintain peak heat transfer for “near new” performance and lower energy costs.
- Reduced coil and drain pan maintenance requirements and costs.
- Satisfies GSA federal facilities standard requirements for UVGI lights to be incorporated downstream of all cooling coils and above all drain pans to control airborne and surface microbial growth and transfer.

## Refrigerant R-407C

McQuay SWP units with independent refrigerant circuits are available with non-ozone depleting R-407C refrigerant.

## Features

- HFC-407C refrigerant is environmentally friendly with zero ozone depleting allowance (ODP).
- ASHRAE Standard 34, Designation and Safety Classification of Refrigerants, classifies HFC-407C as an A1 (lower toxicity—no flame propagation) refrigerant.
- Units are factory engineered for proper cooling performance using R-407C.
- Units are factory charged with R-407C and synthetic oil (such as POE), and they include components and controls specifically tailored to R-407C.
- Units are factory tested prior to shipment.

## Benefits

- HFC-407C allows you to provide your tenants with a comfortable building environment in an environmentally friendly way.
- With no phase out date for production of HFC-407C, a reliable supply should be available for the life of your equipment.

McQuay SWP systems continue to provide industry leading performance, equipped with a complete MicroTech III control system. In addition to providing stable, efficient temperature, and static pressure control, the controller is capable of providing comprehensive diagnostics, alarm monitoring, and alarm specific component shutdown if critical equipment conditions occur. The unit controllers are factory mounted and configured for stand-alone operation or integration with a building automation system (BAS) through an optional communication module with our Open Choices feature.

## Open Choices Benefits for Easy Integration

Easy, low cost integration into most building automation systems without costly gateway panels.

- Flexibility to select either BACnet® or LONWORKS® communication. Units are LonMark® 3.4 certified with the appropriate communications module for LONWORKS networks.
- Comprehensive unit control and status information is available at the BAS regardless of communication protocol.
- Long-term choices for equipment adds or replacements, and for service support.
- Flexible alarm notification and prioritization with Intrinsic Alarm Management (BACnet).
- Simplified BAS integration with the ability to set network parameters at the unit controller, reducing installation time and costs.
- Easy monitoring and troubleshooting of communication status from the unit controller to the BAS.

## Components

Each SWP self-contained system is equipped with a complete MicroTech III unit control system that is pre-engineered, preprogrammed, and factory tested prior to shipment. Each of the MicroTech III unit control systems is composed of several components that are individually replaceable for ease of service.

These components include:

- Unit controller with user interface display and navigation wheel
- Optional expansion modules
- Communication module (optional)
- Pressure transducers
- Unit-mounted temperature sensors
- Zone temperature sensor packages
- Humidity sensor

## Main Control Board (MCB)

The main control board (MCB) contains a microprocessor that is preprogrammed with the software necessary to control the unit. This provides that schedules, set points and parameters are not lost, even during a long-term power outage. The microprocessor board processes system input data and then determines and controls output responses. An RS-232 communication port is provided as standard to allow for direct or modem access with a PC-based service tool.

## Expansion Modules

These boards are used to expand the input and output capability of the unit controller. Each board communicates via serial data communications. These microprocessor based boards provide independent operation and alarm response even if communication is lost with the unit controller.

## Communication Module

An optional communication module provides the means to factory or field configure MicroTech III unit controls for interoperability with an independent BAS. Communication modules are available to support industry recognized communication protocols including BACnet MS/TP, BACnet/ IP and LONWORKS.

## Keypad/Display

All MicroTech III unit controllers include a push/pull navigation wheel and display. The display is a supertwist nematic type with highly visible black characters on a yellow background. The 5-line by 22-character format allows for easy to understand plain English display messages. All operating conditions, system alarms, control parameters and schedules can be monitored from the keypad/display. If the correct password has been entered, any adjustable parameter or schedule can be modified from the keypad.

Figure 12. MicroTech III Keypad/Display MicroTech III Unit Controls



# MicroTech® III Unit Controller

---

## Temperature and Humidity Sensors

With the exception of the zone, outside air and return air sensors, all temperature sensors are factory installed and tested. Zone sensor packages are available to suit any application. A humidity sensor is available for field installation.

## Static Pressure Transducers

All pressure transducers are factory installed and tested. Connection and routing of field-supplied sampling tubes is done at time of unit installation.

## Zone Temperature Sensors

Two optional zone temperature sensors are available:

- Zone sensor with tenant override switch
- Zone sensor with tenant override switch and remote set point adjustment

## Timed tenant override is a standard MicroTech III control feature.

Zone sensors are required for the controller's purge cycle, space reset of supply air set point, and night setback or setup features. All zone sensors are field installed with field wiring terminated at a separate, clearly marked terminal strip.

## Stand-alone Controller Features

MicroTech III applied rooftop unit controls include all of the essential features required to make them capable of completely independent, stand-alone operation.

## Internal Time Clock

An internal, battery-backed time clock is included in the MicroTech III unit controller. Current date and time can be quickly and easily set at the user interface keypad.

## Internal Schedule

Seven daily schedules and one holiday schedule can be entered at the keypad of all unit controllers. For each of these eight schedules, one start and one stop time can be entered. Up to 10 holiday periods, of any duration, can be designated. The unit will automatically run according to the holiday schedule on the holiday dates. To handle special occasions, an additional 'one event' schedule can also be used.

In lieu of its internal schedule, the unit can be operated according to a network schedule from a BAS.

## External Time Clock or Tenant Override Input

An input is supplied that can be used to accept a field wired start/stop signal from a remote source. An external time clock, a tenant override switch, or both may be connected. Whenever the external circuit is closed, the controller overrides the internal schedule (if activated) and places the unit into the occupied mode.

If the internal schedule or a BAS network schedule is used, field wiring is not required.

## Timed Tenant Override

Off-hour operation flexibility is a must in today's office environments and even stand-alone MicroTech III controls handle it with ease. When unit operation is desired during unoccupied hours, initiate timed tenant override by pressing the tenant override button on either of the optional zone sensor packages. The unit then starts and runs in the occupied mode for a keypad-adjustable length of time (up to five hours). If the button is pressed again while the unit is operating, the timer resets to the full time allowance without interrupting unit operation. Tenant override operation also can be initiated by a BAS.

## Three Remote Set Point Adjustment Options

- 1 Remote user interface option (RUI).
- 2 Building automation system (BAS). See "Open Choices Benefits for Easy Integration" on page 11.
- 3 All constant air volume-zone temperature control (CAV-ZTC) unit controllers include an input that can be used to remotely adjust the zone cooling and heating set points. To use this feature, wire the optional zone sensor package with set point adjustment to the controller. The remote set point adjustment feature can be enabled or disabled from the keypad at any time. When enabled, remote set point adjustment is available even if the return temperature is selected to be the Control Temperature.

## Auto/Manual Operation Selection

Automatic or manual operation can be controlled either remotely or at the keypad.

All controllers include three inputs that can be used to enable or disable cooling, heating, and fan operation from remote switches. With the "heat enable" and "cool enable" terminals, the operator can enable cooling, heating, or both as desired. Using the system "off" terminals, the operator can disable the fans, and thus the entire unit.

From the keypad, there are a variety of occupancy and auto/manual control mode selections available to the operator:

- Occupancy modes
  - Auto
  - Occupied
  - Unoccupied
  - Bypass (tenant override)
- Control modes
  - Off manual
  - Auto
  - Heat/cool
  - Cool only
  - Heat only
  - Fan only

## Compressor Lead-lag Selection

All unit controllers are capable of automatic compressor, lead-lag control.

## Waterside Economizer Changeover

On units equipped with a waterside economizer package, the MicroTech III unit controller includes an internal changeover strategy that compares entering cooling tower water temperature to the unit's mixed air temperature. If the entering water temperature is less than the mixed air temperature by a field-adjustable differential (typically 5°F to 7°F), the economizer control valve modulates in response to the cooling load.

## Airside Economizer Changeover Selection

On units equipped with an economizer, there are three methods of determining whether the outdoor air is suitable for free cooling: two methods sense enthalpy (dry bulb temperature and humidity) and one senses outdoor air dry bulb temperature.

The two enthalpy changeover methods use external, factory installed controls. One compares the outdoor ambient enthalpy to a set point; the other is a solid state device that compares the outdoor ambient enthalpy to the return air enthalpy. This comparative enthalpy control can improve total economizer performance.

All unit controls include an internal dry bulb changeover strategy that can be selected at the keypad. When this method is selected, the controller compares the outdoor air dry-bulb temperature to a keypad programmable set point. The external enthalpy control input is then ignored.

## Cooling and Heating Lockout Control

All unit controls include separate keypad programmable set points for locking out mechanical cooling and heating. Mechanical cooling is locked out when the outdoor temperature is below the cooling lockout set point; heating is locked out when the outdoor temperature is above the heating lockout set point. This feature can save energy cost by eliminating unnecessary heating and cooling during

warm-up or cool-down periods or when the outdoor air temperature is mild.

## Night Setback and Setup Control

When one of the zone temperature sensors is connected to the unit controller, night setback heating and night setup cooling control are available. Separate, keypad programmable night heating and cooling set points are used to start the unit when necessary. After the unit starts, night setback and setup control is similar to normal occupied control except that the minimum outside air damper position is set to zero. If the outside air is suitable for free cooling, it is used during night setup operation.

# MicroTech® III Unit Controller

Except for 100% outside air applications, night setback control is available even if the unit is not equipped with any heating equipment. When the space temperature falls to the night setback set point, the fans simply start and run until the temperature rises above the differential. This feature might be useful for applications that use, for example, duct-mounted reheat coils.

## Morning Warm-up Control

If the Control Temperature (space or return) is below set point when the unit enters the occupied mode, the morning warm-up control function will keep the outside air dampers closed while heat is supplied to satisfy set point. The outside air damper will remain closed until either the space temperature rises to the

heating set point or the keypad adjustable morning warm-up timer expires (default is 90 minutes). The morning warm-up timer supplies the minimum required amount of outdoor air after a certain time regardless of the space temperature.

Morning warm-up control is automatically included on all except 100% outside air units. It is available even if the unit is not equipped with any heating equipment, for applications that utilize, for example, duct-mounted reheat coils.

## Condenser Head Pressure Control (units without waterside economizer only)

Mechanical cooling is allowed whenever the entering cooling tower water temperature is 55°F or warmer, without the use of head pressure control. When the entering water temperature is below 55°F, a factory-installed and factory-controlled two-way modulating head pressure control valve can be utilized. The regulating valve is controlled by the MicroTech III controller to maintain refrigerant head pressure.

## Outdoor Air Purge Control (units with airside economizer only)

Purge control is designed to take advantage of cool early morning outside air conditions. It starts the fans and modulates the economizer dampers to maintain occupied cooling requirements during unoccupied periods, if conditions are appropriate. This provides the opportunity to flush the space with fresh outdoor air prior to occupancy. Purge operation is possible only during a keypad-adjustable time window prior to occupancy (0 to 240 minutes). When the purge-cycle is active, mechanical cooling is disabled. To use the purge feature, connect one of the zone temperature sensors to the unit controller. Below is a description of purge control operation.

During the purge time window, the unit starts and runs whenever these three requirements are met:

- The space temperature must be warm enough to enable occupied cooling.
- The outside air enthalpy must be low enough to enable the economizer.
- The outside air temperature must be at least 3°F less than the space temperature.

When any one of these conditions is no longer true, the unit shuts down. As conditions allow, purge cycles the unit in this manner until it enters the occupied mode.

## Proportional Integral (PI) Control

The Proportional Integral (PI) control algorithm controls modulating actuators to maintain a measured variable (temperature or pressure) at or near its set point. For example, it controls economizer dampers to maintain the discharge cooling set point and it controls the supply fan variable frequency drives to maintain the duct static pressure set point. The integral control feature effectively eliminates “proportional droop” (load dependent offset) resulting in the tightest possible control.

For each PI loop, four keypad adjustable parameters allow the control loop to be properly tuned for any application:

- Period
- Dead band
- Proportional band
- Integral time

Appropriate default values for these parameters are loaded into each controller. These default values will provide proper control for most applications; therefore, field tuning is usually not required and thus start-up time is reduced.

## Change Algorithm

The PI function is also used to adjust set points instead of controlling variable speed drives or actuators directly. For example, in zone control applications, the PI loop automatically “changes” the discharge temperature set point (cooling or heating) as the Control Temperature deviates from the zone set point. Another PI loop then controls the economizer actuator or heating valve actuator using the current discharge temperature set point. Unlike a typical “mastersubmaster” reset strategy, this “cascade control” continuously adjusts the discharge set point, even if the Control Temperature’s deviation from set point remains constant. This means that the unit’s cooling or heating output is set according to the actual load, not just the current zone temperature. The tightest possible zone temperature control results because “proportional droop” (load dependent offset) is eliminated.

## Calibrate

When initiated at the keypad by an operator, the Calibrate function automatically calibrates all actuator position feedback inputs and all pressure transducer inputs. It does

this by shutting the unit down and then driving all actuators to the full closed and full open positions. The controller records the input voltage values that correspond to these positions. The pressure transducer input voltages, which are assumed for 0.00-in. W.C., are also recorded. When Calibrate is finished, enter an operator command at the keypad to start the unit.

## Field Output Signals

All MicroTech III controls include two solid-state relay outputs that are available for field connection to any suitable device: the remote alarm output and the occupied output. These two outputs are used to signal field equipment of unit status.

**Remote Alarm Output:** The remote alarm output can be used to operate a 24 volt relay to provide a remote alarm signal to a light, audible alarm, or other device when an alarm condition exists at the unit.

**Fan Operation Output:** The fan operation output is used to operate a 24 volt relay to control field equipment that depends on fan operation; for instance, to open field installed isolation dampers or VAV boxes. To allow actuators enough time to stroke, the fan operation output is energized three minutes before the fans start. It then remains energized until thirty seconds after the unit airflow switch senses no airflow. The fan operation output is on whenever the unit airflow switch senses airflow.

**Outside Air Damper output:** Use to signal an outside air damper actuator to open whenever the unit is in an occupied cooling or heating condition.

## Standard Control Options

SWP Self-Contained systems are available for most any constant or variable air volume application. MicroTech III controls offer three basic control configurations that use sophisticated state change control logic to provide stable, reliable and efficient control:

- Variable air volume with discharge temperature control (DAC)
- Constant air volume with zone temperature control (SCC)
- Constant air volume with discharge temperature control (DAC)

When combined with MicroTech III's many available control capabilities, both factory-installed and keypad-programmable, these three basic configurations can be customized to meet the requirements of the most demanding applications.

## Variable Air Volume with Discharge Temperature Control (DTC)

All VAV units provide true discharge temperature control in addition to duct static pressure control. Cooling only, cooling with single-stage "morning warm-up" heat, and cooling with modulating heat configurations are available.

## Constant Air Volume with Zone Temperature Control (SCC)

SCC units are available in either cooling only or cooling with modulating heat configurations. Either of these configurations is available for 100% recirculated, mixed, or 100% outdoor air applications.

## Constant Air Volume with Discharge Temperature Control (DTC)

DTC units are available in cooling only, cooling with single-stage "morning warm-up" heat, or cooling with modulating heat configurations. This unit configuration can be used for applications that have zone controlled terminal heating coils or for constant volume, 100% outdoor air applications. The discharge temperature control strategies used with the hybrid DTC unit are identical to those used with the DTC unit.

## Discharge Temperature Control

MicroTech III VAV-DTC and CAV-DTC controls provide sophisticated and flexible discharge air temperature control that is only possible with DDC systems. Separate discharge air temperature set points are used for cooling and modulating heating control. At the keypad, the operator can either enter the desired set points or select separate reset methods and parameters for each set point.

## Control Temperature

The Control Temperature makes the heat/cool changeover decision. It determines whether cooling or heating is enabled; the discharge temperature then determines whether cooling or heating is actually supplied. At the keypad, the operator can choose the source of the Control Temperature from among the following selections.

- Space temperature sensor
- Return temperature sensor
- Outside air temperature sensor (modulating heat only)
- Network communication

The operator enters separate cool and heat enable set points and deadbands that the Control Temperature is compared with (see <CrossReference>Figure 13). When the Control Temperature is greater than or equal to the cooling set point plus DB/2, cooling is enabled. When the Control Temperature is less than or equal to the heat set point minus DB/2, heating is enabled. If desired, these set points and differentials can be set so that there is a dead band in which both cooling and heating are disabled. The controller's software prevents simultaneous cooling and heating.

**Figure 13: Control Temperature Logic**

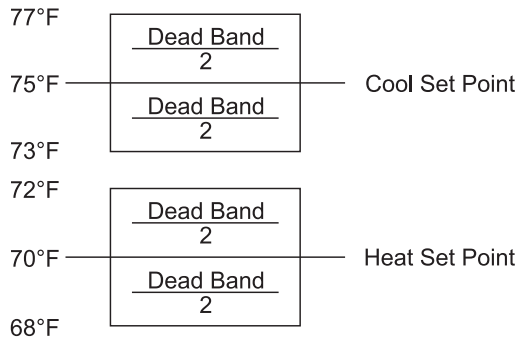

## Proportional Integral Modulation

When operating in economizer free cooling or unit heating, the previously described PI algorithm maintains discharge temperature control. It provides precise control of the economizer dampers, modulating gas heat, steam or hot water valves.

## Compressor Staging

Two staging algorithms are available to control a unit's multiple steps of capacity control, Degree-Time (also known as "average") and Nearest. These control algorithms provide reliable discharge temperature control while managing compressor cycling rates. Constraints on compressor staging are essential for preventing short cycling, which can reduce compressor life by causing improper oil return and excessive heat buildup in the motor windings.

The Degree-Time Compressor staging algorithm keeps track of the discharge temperature and stages cooling up or down to maintain an average temperature that is equal to the discharge cooling set point. A stage change can occur only (1) after the keypad adjustable inter-stage timer has expired (five minute default setting) and (2) if the discharge temperature is outside a keypad programmed dead band. After these two conditions have been met, staging occurs as the controller attempts to equalize two running totals: degree-time above set point and degree-time below set point. The result is that the average discharge temperature is maintained at the cooling set point.

The Nearest Compressor staging algorithm keeps track of the discharge temperature and stages cooling up or down to maintain the discharge temperature as close as possible to set point. A stage change can occur only (1) after the keypad adjustable inter-stage timer has expired (five minute default setting) and (2) if the control logic calculates that a stage change will result in a discharge temperature closer to set point than the existing condition. The controller logic continually calculates the expected effect of a stage change and uses this information before making a change. A change is made only if it will bring the discharge temperature closer to set point, resulting in a more consistent discharge temperature, reduced compressor cycling and more stable control VAV box control.

## Supply Air Reset

By automatically varying the discharge air temperature to suit a building's cooling or heating needs, supply air temperature reset can increase the energy efficiency of VAV and CAV-DTC systems. MicroTech III controllers offer a variety of different reset strategies that can be selected at the keypad. Because they are keypad programmable, reset strategies can be changed or eliminated as desired. Separate strategies can be selected for both cooling and modulating heat. If reset is not desired, a fixed discharge cooling or heating set point can be entered.

The following reset methods are available:

- Space temperature
- Return temperature
- Outdoor air temperature
- Supply airflow (VAV, cooling set point only)
- External 0–10 VDC or 0–20 mA signal
- Network communication

For all temperature reset methods, the minimum and maximum cooling and heating set points are keypad programmable along with the corresponding minimum and maximum space, return or outdoor air temperature parameters. For the supply airflow method, the discharge set point will be reset as the supply fan modulates between 30% adjustable and 100% adjustable. For the external method, the discharge set point will be reset as the voltage or current signal varies over its entire range. For units in a BAS network, the discharge set points are reset via the communication signal.

## Zone Temperature Control

MicroTech III CAV-ZTC controls provide the sophisticated and flexible zone temperature control that is only possible with DDC systems. Zone temperature sensors are available with or without a remote set point adjustment. With the remote adjustment model, the space set point can be set at the keypad or at the zone sensor package. Even if a zone sensor is connected, remote set point adjustment can be enabled or disabled as desired at the keypad.

## Control Temperature

The Control Temperature is the representative zone temperature. When compared with the zone set points, the Control Temperature determines whether the unit supplies heating, cooling, or neither. It also determines the amount of cooling or heating required to satisfy the load. Its source can be selected at the keypad from among the following selections:

- Zone temperature sensor
- Return temperature sensor

Because it is the representative zone temperature, the Control Temperature is the primary input to the MicroTech III zone temperature control algorithms. Control Temperature parameters are described below. The controller's software will prevent cooling and heating from being inadvertently enabled at the same time.

## Change and Proportional Integral Modulation

When economizer "free" cooling or unit heating is required, the two MicroTech III PI loops combine for cascade-type control, providing the tightest possible zone temperature control. By controlling the discharge temperature along with the zone temperature, these functions eliminate temperature variations near the diffusers that could otherwise occur as a result of traditional zone control's inherent lag effect.

**Change:** If the Control Temperature is above or below the set point by more than the dead band, the Change PI loop periodically adjusts the cooling or heating discharge air temperature set point either up or down as necessary. The amount of this set point change corresponds to the Control Temperature's position in the modulation range. The farther the Control Temperature is from the set point, the greater the discharge set point change will be. The Change-adjusted discharge cooling and heating set points are limited to ranges defined by keypad programmable maximum and minimum values.

**PI:** Using the Change function's current discharge set point, the PI function maintains precise discharge temperature control by modulating the economizer dampers and gas heat, steam or hot water heating valves.

## Compressor Staging

Compressor staging is controlled directly by the Control Temperature. When the Control Temperature is warmer than the zone cooling set point, cooling is staged up; when the Control Temperature is cooler than the zone cooling set point, cooling is staged down. However, a stage change can only occur when the Control Temperature is outside the dead band (see <CrossReference>Figure 14). Staging is constrained by an inter-stage delay timer (five minute default setting) and minimum and maximum discharge air temperature limits (all keypad programmable). These constraints protect the compressors from short cycling while eliminating temperature variations near the diffusers.

**Figure 14: Compressorized Logic**

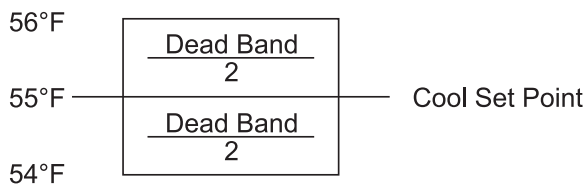

## Project Ahead Algorithm

Because the inherent lag effect in zone temperature control applications can cause overshoot during warm-up or cool-down periods, MicroTech III features a "Project Ahead" control algorithm. Project Ahead calculates the rate at which the Control Temperature is changing and reduces the unit's cooling or heating output as the zone temperature nears its set point, essentially eliminating overshoot.

## Duct Static Pressure Control

On all VAV-DTC units, duct static pressure control is maintained by the PI algorithm, which provides precise control of the supply fan variable speed drive. The keypad programmable set point can be set between 0.20-in. W.C. and 4.00-in. W.C.

On larger buildings with multiple floors, multiple trunk runs or large shifts in load due to solar effects (east/west building orientation), an optional second duct static sensor is offered. The MicroTech III controller automatically selects and uses the lower of the two sensed pressures to control fan volume to provide adequate static pressure to the most demanding space at all times.

## Operating States

Operating states define the current overall status of the self-contained system. At the user interface, the operator can display the current operating state and thereby quickly assess the unit's operating condition.

## Alarm Management and Control

MicroTech III unit controllers are capable of sophisticated alarm management and controlled response functions. Each alarm is prioritized, indicated, and responded to with the appropriate action. The active alarm (up to 10 alarms, arranged by alarm priority) and previous alarm (up to 25 alarms, arranged by date/time cleared), each with a time and date stamp, can be displayed at the user interface. Generally speaking, whenever a current alarm is cleared, it is logged as a previous alarm and the oldest previous alarm is removed.

## Alarm Priority

The various alarms that can occur are prioritized according to the severity of the problem. See <CrossReference>Table 1. Three alarm categories are used: faults, problems, and warnings.

- 1 Faults are the highest priority alarms. If a fault condition occurs, the complete unit shuts down until the alarm condition is gone and the fault is manually cleared at the keypad. A fault example is Fan Fail alarm.

# MicroTech® III Unit Controller

- 2 Problems are the next lower priority to alarms. If a problem occurs, the complete unit does not shut down, but its operation is modified to compensate for the alarm condition. A problem automatically clears when the alarm condition that caused it is gone. Compressor Fail is an example of a problem where only the affected compressor is shut down.
- 3 Warnings are the lowest priority alarms. No control action is taken when a warning occurs; it is indicated to alert the operator that the alarm condition needs attention. To make sure that they are read, the operator must manually clear all warnings. Dirty Filter indication is an example of a warning.

Generally, a specific alarm condition generates an alarm that falls into only one of these categories. Under different sets of circumstances, however, the freezestat and most of the sensor failure alarm conditions can generate alarms that fall into multiple categories.

### Adjustable Alarm Limits

Four alarm indications have adjustable limits that are used to trigger the alarm. The high return temperature alarm and the high and low supply temperature alarms are adjusted at the user interface. The dirty filter alarm(s) is adjusted at the sensing device.

**Table 1: MicroTech III Alarm Summary**

Alarm Name	Fault	Problem	Warning
Freeze	X	X	
Smoke	X		
Temperature Sensor Failure	X	X	
Duct High Limit	X		
High Return Temperature	X		
High Discharge Temperature	X		
Low Discharge Temperature	X		
Fan Failure	X		
Fan Retry		X	
Discharge Air Capacity Feedback	X		
Economizer Stuck	X	X	
Auxillary Control Board Enabled		X	
Low Airflow		X	
Circuit 1–8 High Pressure		X	
Circuit 1–8 Low Pressure/Frost		X	
Compressor 1–8 Motor Protection		X	
Compressor 1–8 Failure		X	
Airflow Switch (False Airflow)			X
Dirty Filter			X

The following section contains basic application and installation guidelines which must be considered as part of the detailed analysis of any specific project.

## General

Units are intended for use in normal heating, ventilating and air conditioning applications. Consult your local McQuay sales representative for applications involving operation at high entering condenser water temperatures, high altitudes, non-cataloged voltages and for applications requiring modified or special control sequences. Consult your local McQuay sales representative for job specific unit selections that fall outside of the range of the catalog tables, such as 100% outside air applications.

For proper operation, rig units in accordance with instructions stated in IM 709.

Factory check, test and start procedures must be explicitly followed to achieve satisfactory start-up and operation (see IM 709).

Many self-contained system applications take advantage of the significant energy savings provided by the use of economizer operation. When a water economizer system is used, mechanical refrigeration is typically not required below an entering condenser water temperature of 55°F. Standard McQuay self-contained systems are designed to operate with entering water temperatures down to 50°F when a water economizer is used and 55°F with no water economizer. For applications where a water economizer system cannot be used, a modulating head pressure control system is available to permit operation at entering condenser water temperatures below 55°F.

## Unit Location

Make sure that the floor is structurally strong enough to support the unit with minimum deflection (See "Unit and Component Weights in lbs." on page 42). Provide proper structural support to minimize sound and vibration transmission. A concrete floor should be considered. Extra caution is required when installing on a wooden structure. Units must be installed level from front-to-back and over their length.

Unit fresh air intakes must be located away from building flue stacks, exhaust ventilators and areas containing automotive or other exhaust to prevent the possible introduction of contaminated air to the system. Consult code requirements for minimum fresh air volumes.

Allow sufficient space around the unit for service and maintenance clearance. Refer to Figure 15 for recommended service/maintenance clearances. See also "Recommended Clearances" on page 19. Locate equipment room access doors in a manner that can assist in service access if needed (i.e., coil removal). Contact your local McQuay sales representative if reduced service/maintenance clearances are required.

Where code considerations, such as the NEC, require extended clearances, they take precedence over minimum service/maintenance clearances.

## Acoustical Considerations

Good acoustical design is a critical part of any successful installation and should start at the earliest stages in the design process. Each of the four common sound paths must be addressed. These are: (1) radiated sound through the casing of the unit, (2) structure borne vibration, (3) airborne sound through the supply air duct and (4) airborne sound through the return air duct.

Some basic guidelines for good acoustic performance include:

1. Always provide proper structural support under the unit.
2. Provide adequate mass in the floor structure, especially when located over an occupied space where good acoustics are essential.
3. Seal all supply and return air duct penetrations once the duct is installed.
4. Don't overlook the return air path. Always include some duct work (acoustically lined tee) at the return inlet.
5. Minimize system static pressure losses to reduce fan sound generation.
6. Select the appropriate unit/fan for the application. Fans should be selected as close as possible to their peak static efficiency. To assist you, peak static efficiency is identified by the first system curve to the right of the shaded "Do not select" region on each fan curve.
7. Design duct systems to minimize turbulence.
8. Account for low frequency duct breakout noise in system design. Route the first 20' of rectangular duct over non-sensitive areas and avoid large duct aspect ratios. Consider round or oval duct to reduce breakout.

## Recommended Clearances

For good installation, service and maintenance access, follow recommended clearances. Minimum clearances required by local, state or federal codes, such as the NEC, take precedence over those listed below. Clearance is required to allow room for side filter access, mechanical cleaning of condenser tubes and economizer coil access to expansion valves and other control components and to allow for possible fan shaft or compressor removal.

Unit Front	42 inch
Unit Rear	24 inch
Motor Location Side	36 inch
Piping Location Side	36 inch
Side Without Motor or Piping	24 inch
Clearance at Face of VFD	42 inch

For clearance requirements less than those indicated, consult your local McQuay sales representative.

# Application Considerations

Figure 15. Recommended Service/Maintenance Clearances

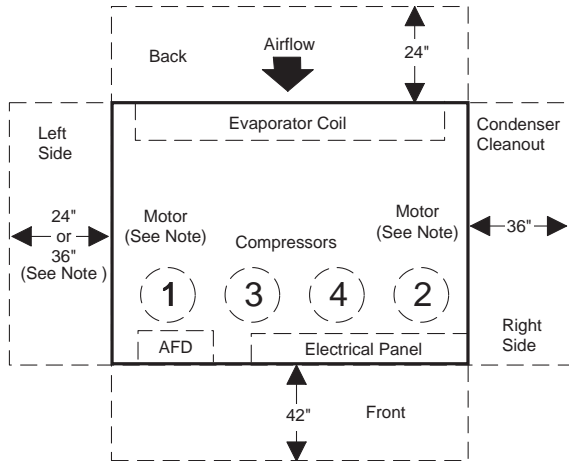

**Note:** 36 inches are required if water and condensate drain connections are left-hand, or fan discharge arrangement is back.

## Equipment Room

Locate the equipment room away from sound sensitive areas. Whenever possible, isolate the equipment room from these areas by locating rest rooms, utility rooms, stairwells, hallways, elevators, etc., around its perimeter. This allows not only isolation from radiated sound but provides the capability to route ductwork over less sensitive areas.

Acoustically seal the equipment room. All equipment room penetrations should be sealed with a high quality, flexible material to prevent air and noise from escaping. Even a small leak will compromise the acoustic performance of the installation. The equipment room door should seal tightly on a perimeter gasket.

Equipment room wall construction should be concrete block or offset, double stud. The decision will depend on the critical nature of the application. If offset, double stud construction is used the cavity should be lined with glass fiber insulation and a double layer of sheetrock used on each side of the wall.

## Ductwork

Fan noise can be carried through the ductwork to occupied spaces and likely will be the most challenging to control. Careful duct design and routing practice is required. The ASHRAE Applications Handbook discusses sound attenuation relevant to self-contained system applications. Contact your local McQuay sales representative for sound power data for designing the appropriate sound levels for your specific application.

## Return Duct

The return duct is the most often over looked. Return air can be ducted directly to the unit or ducted into the equipment room. If ducted to the equipment room, an elbow should be installed within the equipment room. Running a return air drop to near the floor of the room will provide added attenuation. A length of lined ductwork should extend from the equipment room to a length of 15 feet. The maximum recommended return air duct velocity is 1000 feet per minute.

## Supply Duct

A lined section of supply air duct should extend at least 15 feet from the equipment room. The use of round duct should be reviewed as it will significantly reduce low frequency sound near the equipment room. If rectangular duct is used, the aspect ratio of the duct should be kept as small as possible. The large flat surfaces associated with large aspect ratios will transmit sound to the space and the potential for duct generated noise, such as oil canning, is increased. The maximum recommended supply air duct velocity is 2000 feet per minute.

When direct ducting to the fan outlet, a minimum of two fan diameters from the fan outlet is recommended and the elbow should turn in the direction of fan rotation. Abrupt turns, takeoffs, etc., will generate air turbulence and resulting unwanted sound and should be avoided.

## Duct Protection

An adjustable duct high limit switch is standard equipment on all SWT system's with VAV controls. This is of particular importance when fast acting, normally closed boxes are used. The switch is field adjustable and must be set to meet the specific rating of the system ductwork.

## Vibration Isolation

Duct connections to the unit or to the acoustic discharge plenum should be made with a flexible connection. Flexible piping and electrical connections should not be required, but attention should be paid to these areas to avoid vibration transmission from outside sources to the SWT unit.

## Condenser Water Piping

Always follow good industry practice in the design of the water piping system. Attention to water treatment and proper strainer application are always necessary. All SWT systems feature mechanically cleanable condensers and optional waterside economizer coils. In addition to mechanically cleanable heat exchangers, cleanouts are provided in the interconnecting piping and in the internal condensate drain trap. Costly field traps are not required. To allow periodic cleaning of the condensers and economizer coils, isolation valves should be provided. Condensers, economizer coils and hot water coils are provided with vent and drain connections.

Always review for possible requirements for condenser piping insulation, especially if cold entering condenser water conditions (<55°F) will be experienced.

## Head Pressure Control

If cold entering condenser water conditions (<55°F) will be experienced, a waterside economizer or a condenser head pressure control valve is required. A 2-way, head pressure activated control valve is available factory installed for these applications. A head pressure control valve is not required when the SWT unit is applied with factory waterside economizer package.

## Variable Air Volume

Variable frequency drives offer reliable speed control over a wide range of airflow, with advantages in sound and energy performance. In addition, McQuay offers the ability to sense duct static pressure in multiple locations, enhancing control accuracy and helping minimize energy use.

## Variable Frequency Drives

Variable frequency drives provide the most efficient means of variable volume control by taking advantage of the fan law relation between fan speed (rpm) and fan brake horsepower (bhp). Also, since airflow reduction is accomplished by changing fan speed, the noise penalties often associated with mechanical control devices, e.g. inlet vanes, are not introduced. The following equation illustrates how fan bhp varies as the cube of the change in fan speed:

$$hp_2 = hp_1 \left( \frac{\text{density}_2}{\text{density}_1} \right) \left( \frac{\text{rpm}_2}{\text{rpm}_1} \right)^3$$

In an ideal system, at 50% fan speed, brake horsepower would be reduced to 12.5% of that at full speed.

Variable frequency control varies the speed of the fan by adjusting the frequency and voltage to the motor. Keeping a constant volts/frequency ratio (constant magnetic flux) to the motor allows the motor to run at its peak efficiency over a wide range of speeds and resulting fan airflow volumes.

## Duct Static Pressure Sensor Placement

The static pressure should be sensed near the end of the main duct trunk(s). The MicroTech III static pressure control should be adjusted so that at full airflow all of the terminals receive the minimum static pressure required plus any downstream resistance.

Control is to the lowest static pressure set point that will satisfy airflow requirements. Lower static pressure setpoints will reduce fan brake horsepower requirements and fan sound generation.

The static pressure sensor tap should be located in the ductwork in an area free from turbulence effects and at least 10 duct diameters downstream and several duct diameters upstream from any major interference, including branch takeoffs. The SWT MicroTech III control system can receive a second duct static pressure sensor in installations having multiple duct trunks or significantly varying zones. The control logic will maintain static pressure at both sensors.

## Zone Sensor Placement

Placement of the zone temperature sensor is extremely important to provide proper and economical operation of the heating and cooling system. It is generally recommended that the space sensor be located on an inside wall (3 to 5 feet from an outside wall) in a space having a floor area of at least 400 square feet. The sensor should not be located below the outlet of a supply air diffuser, in the direct rays of the sun, on a wall adjacent to an unheated or abnormally warm room (boiler or incinerator room), or near any heat producing equipment. Where zone sensor placement is a problem, all SWT zone control systems have, as standard, the capability to use the return air sensor for heating & cooling control.

## Filtration

Filters should be routinely replaced to minimize filter loading. As filters get dirty, the filter pressure drop increases, affecting system airflow and energy requirements. Depending on fan type, forward curved or airfoil, this airflow change can be significant. The effect of filter loading is the most critical when using high efficiency filters.

When making a fan selection, a pressure drop component for filters as they get dirty should be included in the system total static pressure. A value midway between clean and dirty filter ratings is recommended. If a minimum airflow is critical, the fan selection should be made using the higher, dirty filter pressure drop value. For VAV systems, consider setting the fan control device such that part of its modulation range can be used to maintain airflow as filters become dirty. Following these recommendations should limit airflow fluctuation as the filters load.

## System Operating Limits

SWT units can be applied in a wide range of system needs. High cfm/ton or high/low discharge temperature applications are available. However, for proper system operation, some application limits do apply.

### Airflow

Maximum cfm limits, based on coil face velocity, are given Table 4 on page 25.

Separate minimum design cfm limits, by unit size, are given in the physical data table for constant and variable air volume applications. Fan modulation should be limited to 40% of the minimum design cfm limit. Minimum airflow conditions are also dependent on fan selection criteria. Contact your McQuay sales representative to answer any questions on minimum airflow capability or for conditions not shown in the catalog.

VAV box minimum airflow settings should correspond with the minimum VAV fan operating point. All units are provided with multi-groove, fixed pitch sheaves. During system air balance, alternate fixed pitch sheaves may be needed to match final system requirements. Alternate sheaves are available from McQuay.

### Fan Heat

Sensible heat gain from the fan, fan motor and drives occurs in all fan systems and its effect must be considered during equipment selection. It is an added load in cooling and an added source when in heating. The majority of the heat gain occurs through the fan itself, as the air is elevated from the low-pressure side to the high-pressure side of the fan. Moving the motor out of the air stream has a negligible effect on overall fan heat gain. A unit with higher fan power requirements/higher fan heat will have less net cooling capability and may not have enough left to satisfy system loads.

As a "rule of thumb," a typical supply fan heat gain is 3°F. However, fan heat gain can be quickly calculated once the fan has been selected and the fan brake horsepower has been determined.

Using Figure 16, "Fan & Motor Heat Gain", select your fan brake horsepower on the horizontal axis, move up vertically until you intersect with the heat gain curve and then move horizontally to find the fan heat gain in Mbh.

# Application Considerations

Figure 16. Fan and Motor Heat Gain

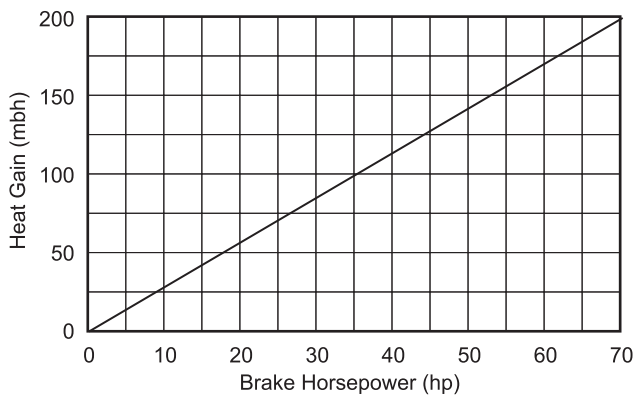

$$\text{Fan Temperature rise} = \frac{\text{Fan Heat (Mbh)}}{1.085 \times \text{Fan cfm}}$$

A draw through unit has the fan located after the DX cooling coil. In this arrangement, fan heat is applied as reheat to the cold, conditioned air coming off of the coil. This arrangement will have a lower sensible heat ratio and higher dehumidification capability than a blow through coil arrangement. The discharge temperature available to the supply duct is always the sum of the coil leaving air temperature plus the fan temperature rise. This must be considered when selecting the supply air volume required to satisfy space requirements.

Example:

52°F leaving coil temp.

+ 3°F fan temp. rise = 55°F discharge air temp.

## Condenser Water Flow

System capacity tables provide selections for a condenser flow rate of 3 gpm/ton. For a given entering condenser water temperature, 3 gpm/ton will provide maximum unit performance. Reducing condenser water flow rates to 2.5 or 2 gpm/ton can significantly reduce pumping energy costs and reduce piping costs. The reduction in pumping energy can be compared to the change in unit performance and an evaluation made. The SWT capacity tables can be used for condenser flow rates from 2 to 3 gpm/ton by using the appropriate leaving condenser water temperature column (interpolation is allowed). Minimum condenser flow rate is 2 gpm/ton.

## Coil Freeze Protection

Consideration must always be made for coil freeze protection when applying units in geographic areas which see subfreezing temperatures. Careful design of outside air/return air mixing systems is critical to minimizing freeze potential. Some applications may require the use of glycol and/or preheat coils. No control sequence can prevent coil freezing in the event of power failure.

A nonaveraging type freeze-stat is factory installed on all units with hot water heat or waterside economizer. If a potential freeze condition is sensed, unit water valves will be driven to the full open position, the supply fan de-energized and an alarm signal sounded.

In nonducted return applications where the equipment room is the mixing plenum, some form of heat within the equipment room should be considered.

## Air Density Correction

Fan performance data is based on standard 70°F air temperature and zero feet altitude (sea level). For applications other than standard, a density ratio must be multiplied to actual static pressure values. Density correction factors are expressed as a function of temperature and altitude in Table 2.

Table 2. Temperature and altitude conversion factors

AIR TEMP	ALTITUDE (FEET)								
	0	1000	2000	3000	4000	5000	6000	7000	8000
-20°F	1.20	1.16	1.12	1.08	1.04	1.00	0.97	0.93	0.89
0°F	1.15	1.10	1.08	1.02	0.99	0.95	0.92	0.88	0.85
20°F	1.11	1.06	1.02	.998	0.95	0.92	0.88	0.85	0.82
40°F	1.06	1.02	0.98	0.94	0.91	0.88	0.84	0.81	0.78
60°F	1.02	0.98	0.94	0.91	0.88	0.85	0.81	0.79	0.76
70°F	1.00	0.96	0.93	0.89	0.86	0.83	0.80	0.77	0.74
80°F	0.98	0.94	0.91	0.88	0.84	0.81	0.78	0.75	0.72
100°F	0.94	0.91	0.88	0.84	0.81	0.78	0.75	0.72	0.70
120°F	0.92	0.88	0.85	0.81	0.78	0.76	0.72	0.70	0.67
140°F	0.89	0.85	0.82	0.79	0.76	0.73	0.70	0.78	0.65

## Unit Wiring

All units require 3-phase, 60 Hz, 208, 230, 460 or 575 volt power or 3-phase, 50 Hz, 400 volt power. Units will operate satisfactorily at ±10% of rated voltage at the power connection terminals of the unit. All units include individual branch circuit fusing of all motor loads and have a single-point power connection. A factory mounted, nonfused disconnect switch is an available option.

All wiring must be installed in accordance with the NEC and local codes.

Achieving the optimal performance of any system requires both accurate system design and proper equipment selection. Factors which control unit selection include applicable codes, ventilation and filtration requirements, heating and cooling loads, acceptable temperature differentials and installation limitations. McQuay SWT units offer a wide selection of component options providing the capability to meet diverse application needs.

The McQuay SelectTools™ software selection program allows your local McQuay sales representative to provide you with fast, accurate and complete selection of McQuay SWT units. Unit selection can also be accomplished through reference to physical, performance, dimensional and unit weight data included in this catalog. Due to the variety of cooling system options available, only a sampling of cooling capacity data has been presented in this catalog.

Proper equipment selection can be accomplished by following these three simple steps:

1. Select unit size and compressor combination.
2. Selecting heating system.
3. Select fan and motor.

The following example is provided to illustrate the catalog selection procedure

## Selection Example:

### Scheduled Design Requirements:

Supply air volume	12,000 cfm
Maximum face velocity	550 fpm
Supply fan external SP	2.00" w.g.
Altitude	sea level
Variable air volume system with fan speed control	
Hot water heat	
Water economizer system	
30% pleated filters	
460V/60Hz/3Ph	
Double wall construction	
Stainless steel drain pan	
Premium efficiency motor	

### Summer Design:

DX coil mixed air dry bulb	80°F
DX coil mixed air wet bulb	67°F
Sensible load	345,000 Btu/hr
Total load	450,000 BTU/hr
Supply fan sensible heat rise	3°F
Entering condenser water	85°F
Leaving condenser water	95°F
Minimum condenser water	55°F

### Winter Design:

Return air temperature	60°F
Space heating load	450 mbh
Entering hot water temperature	180°F

### Step 1 - Unit Size Selection

Unit size is based on coil face area and cooling capacity requirements. Supply air capacity and maximum face velocity constraints should serve as a guide for selecting coil dimensions and cabinet size.

Based on the given data, the appropriate coil face area may be determined as follows:

$$\begin{aligned} \text{Minimum face area} &= \text{supply air volume} / \text{maximum face velocity} \\ &= 12,000 \text{ cfm} / 550 \text{ fpm} \\ &= 21.8 \text{ square feet} \end{aligned}$$

**Note:** Unit data is based on standard air conditions of 70°F at sea level. See "Application Considerations" on page 20 for temperature/altitude conversion factors for non-standard conditions.

Referring to Table 4 on page 25 under the Physical Data section, the 23.3 square foot coil of the SWT040C satisfies the requirements.

### Step 2 - Unit DX Cooling Selection

Since the design cfm is less than the nominal value in the DX Cooling Capacity Data table, the capacities must be adjusted. See Table 5. DX Cooling Capacity Correction Multipliers on page 26.

*CFM correction factor =*

$$\text{design cfm} / \text{nominal cfm} = 12,000 / 14,000 = .857$$

*Total heat correction multiplier = .973*

$$\text{Capacity required from table} = 450 \text{ mbh} / .973 = 462.5 \text{ mbh}$$

*Sensible heat correction multiplier = .929*

$$\text{Capacity required from table} = 345 \text{ mbh} / .929 = 371.4 \text{ mbh}$$

Using the "DX Cooling Capacity Data" tables provided, the unit selection is a SWT040C with (1) 6hp and (3) 10hp compressors. Unit performance from the table equals 512.8 TMBH/375.9 SMBH at 123gpm. Adjusting for the lower cfm yields:

$$\text{Total capacity} = 512.8 \text{ MBH} \times .973 = 499.0 \text{ MBH}$$

$$\text{Sensible capacity} = 375.9 \text{ MBH} \times .929 = 349.2 \text{ MBH}$$

$$\text{Coil LAT} = 80^\circ \text{ F} - 349.2 \text{ MBH} / (1.085 \times 12,000 \text{ cfm}) = 53.2^\circ \text{ F}$$

$$\text{Condenser flow rate} = 123 \text{ gpm} \times .973 = 120 \text{ gpm}$$

### Step 3 - Economizer Capacity Selection

Determine the Waterside Economizer Capacity by referring to Table 18 on page 30. Use entering air of 80/67°F and entering water of 55°F at 120 gpm. Interpolating for the required gpm, economizer performance equals 276.3 TMBH / 261.9 SMBH at the unit's nominal cfm. Using the Waterside Economizer Capacity Correction Factors (Table 6 on page 26), performance at the specified cfm can be found.

$$\text{Total capacity} = 276.3 \text{ MBH} \times 0.943 = 260.6 \text{ MBH}$$

$$\text{Sensible capacity} = 261.9 \text{ MBH} \times 0.904 = 236.8 \text{ MBH}$$

# Selection Procedure

## Step 4 - Heating Selection

Determine hot water capacity from Table 19 on page 31. After interpolating for the specified cfm, Table 19 indicates a total of 457mbh.

## Step 5 - Fan/Motor Selection

Fan/motor selection is based on unit total static pressure and design airflow. Total static pressure includes the internal air pressure drops of unit components and external air pressure drops of supply and return air duct systems. See "" on page 31 for internal pressure drops of unit components. Values in the table may be interpolated for the specified cfm.

Internal pressure drops:

DX coil (wet surface)	0.68" w.g.
Economizer coil (dry surface)	0.38" w.g.
Hot water coil	0.11" w.g.
4", 30% efficient filters	0.19" w.g.
<b>Total internal pressure drop</b>	<b>1.36" w.g.</b>

External pressure drop:

Supply + return duct	2.00" w.g.
----------------------	------------

$$\begin{aligned} \text{Total static pressure} &= \text{internal drops} + \text{external drops} \\ &= 1.34" + 2.00" \\ &= 3.36" \text{ w.g.} \end{aligned}$$

Entering the fan curve for the SWT040C at 12,000cfm and 3.75" w.g., yields 13.0 required fan brake horsepower. A 15 horsepower motor can be selected.

## Step 6 - Calculating Unit Weight

Referring to Table 29 on page 42, for a SWT040C:

$$\begin{aligned} \text{Unit weight} &= \text{SWT basic unit} + 6 \text{ row evaporator coil} \\ &+ \text{economizer coil} + \text{water (econ. coil)} \\ &+ \text{hot water coil} + \text{water (HW coil)} + [(1) 6 \text{ hp,} \\ &(3) 10 \text{ hp}] \text{ compressor / condenser} \\ &+ \text{water (condenser) SAF} + \text{SAF motor} + \text{VFD} \\ &= 1473 + 450 + 410 + 111 + 152 + 32 + 1233 + 74 + 1120 + 185 + 50 \\ &= 5,290 \text{ Lbs.} \end{aligned}$$

## Step 7 - Supply Power Wiring

Sizing supply power wire for a unit is based on the circuit with the highest amperage draw. All electrical equipment is wired to a central control panel for either single or optional dual power connections. See "" on page 40 for FLA and RLA ratings. Determine Minimum Circuit Ampacity (MCA) as follows:

$$\text{MCA} = [1.25 \times \text{RLA or FLA of largest motor}] + [1.00 \times \text{RLA or FLA of all other loads}] + [2 \text{ amps (controls)}]$$

	RLA/FLA
(1) 6 horsepower compressors	8.1 amps each
(3) 10 horsepower compressors	14.1 amps each
15 horsepower premium efficiency supply fan motor	18.9 amps

$$\text{MCA} = [1.25 \times 18.9] + [(8.1 + 14.1 + 14.1 + 14.1)] + [2] = 76.0 \text{ amps}$$

**Note:** If a unit has been selected with non-concurrent electric heat, MCA must be calculated for both the heating mode and the cooling mode and the **larger** value used.

## Step 8 - R-407C Performance

The cooling tables (starting on page 26) document the old R-22 cooling capacity and compressor kW. The R-407C performance correction factors vary slightly with the unit size and operating conditions but can be estimated as shown in the table below. Use the McQuay SelectTools™ computer selection program to obtain the exact R-407C performance.

Table 3. R-407C correction factor

Compressor capacity
0.96 to .98

Table 4. SWT 018C Through SWT 040C

Data	SWT Model Size				
	018C	023C	028C	035C	040C
<b>Compressor</b>					
Quantity	4	4	4	4	4
Size	See DX Cooling Capacity Tables				
<b>Evaporator Coil</b>					
Face Area (Ft. <sup>2</sup> )	11.8	15.3	18.9	23.3	26.3
Rows	4, 6	4, 6	4, 6	4, 6	4, 6
Fpi	12	12	12	12	12
<b>Performance<sup>a</sup></b>					
EER / IPLV	13.33	13.95	14.7	13.47	13.27
<b>Waterside Economizer Coil</b>					
Face Area (Ft. <sup>2</sup> )	11.8	15.3	18.9	23.3	26.3
Rows	4	4	4	4	4
FPI	12	12	12	12	12
Maximum Working Pressure (psig)	400	400	400	400	400
<b>Hot Water Heating Coil</b>					
Face Area (Ft. <sup>2</sup> )	9.3	12.8	16.3	20.2	23.8
Rows	1, 2	1, 2	1, 2	1, 2	1, 2
Fpi	12	12	12	12	12
<b>Electric Heat</b>					
Kw	34	34	34	34	34
<b>Filters</b>					
(Qty) size (in) 4" depth	(3) 20 x 20	(3) 20 x 20	(3) 20 x 20	(5) 20 x 20	(5) 20 x 20
	(2) 25 x 20	(2) 25 x 20	(2) 25 x 20	(5) 25 x 20	(5) 25 x 20
	(4) 16 x 25	(4) 16 x 25	(4) 16 x 25		
<b>Evaporator Fan<sup>b</sup></b>					
Quantity	1	1	1	2	2
Size	15	18	18	15	15
Minimum Horsepower	5	7.5	10	10	15
Maximum Horsepower	10	15	20	20	25
Minimum Design cfm, CV	2950	3825	4725	5825	6575
Minimum Design cfm, VAV	4720	6120	7560	9320	10520
Maximum Design cfm	7080	9180	11340	13980	15780
<b>Condensers</b>					
Waterside Working Pressure (psig)	400	400	400	400	400
Minimum Entering Temperature (°F) Mechanical Cooling	55	55	55	55	55
Minimum GPM	25	41	53	66	69
Maximum GPM	88	108	125	159	166

a. Based on ARI 340/360-93 standard rating conditions, 80/67°F to the coil, 85-95° condenser water.

b. Standard fan TSP limit is 5.5 inches of water. Consult your local McQuay sales representative for applications beyond this range.

# Performance Data

## Unit Efficiency Ratings

### Correction Multipliers

#### DX Cooling Capacity Correction Multipliers

Table 5. DX Cooling Capacity Correction Multipliers

Description	Percent Standard Cfm								
	-20%	-15%	-10%	-5%	Std.	+5%	+10%	+15%	+20%
Total Heat	0.968	0.971	0.985	0.991	1.000	1.006	1.012	1.019	1.025
Sensible Heat	0.900	0.925	0.952	0.974	1.000	1.024	1.048	1.070	1.093
Compressor Motor Kw	0.980	0.985	0.989	0.995	1.000	1.004	1.006	1.011	1.017

#### Waterside Economizer Capacity Correction Factors

Table 6. Waterside Economizer Capacity Correction Factors

	Cfm Compared To Rated Quantity	Total Cooling Capacity Multiplier	Sensible Cooling Capacity Multiplier
Waterside Economizer	-20%	0.920	0.870
	-10%	0.960	0.930
	STD.	1.000	1.000
	+10%	1.04	1.06
	+20%	1.08	1.12

#### 50 Hertz

For 50 Hz applications, the total capacity must be derated by 0.89 and the sensible capacity must be derated by 0.94. The 50 Hz supply fan motor horsepower selections must be based on fan brake horsepower (from Figure 21 through Figure 29) divided by 0.8.

## DX Cooling Capacity Data

### SWT023C - 8000 CFM

Table 7. SWT023C - 8000 CFM (4 Compressors)

Compressors	EDB(°F)	EWB(°F)	EWT(°F)	TMBH	SMBH	LDB	LWB	GPM
(4)6HP	75	62	75	298.6	230.4	48.6	48.4	71
			85	289.3	226.1	49.1	48.9	70
			95	279.3	221.7	49.6	49.4	70
	80	67	75	323.3	227.1	54.0	53.8	76
			85	313.0	223.0	54.4	54.3	75
			95	302.3	218.7	54.9	54.8	75
	85	72	75	349.9	223.3	59.4	59.2	82
			85	339.0	219.4	59.9	59.7	81
			95	327.5	215.3	60.3	60.2	80

**Note:** See Table 5 DX Cooling Capacity Correction Factors on page 26 for determining unit capacity at other than nominal cfm. For a computer generated job specific selection, contact your local McQuay sales representative. For 50 Hz applications, the total capacity must be derated by 0.89 and the sensible capacity must be derated by 0.94. All capacities are gross and do not account for fan motor heat. Altitude and/or Glycol selections also available.

## SWT028C - 10,000 CFM

Table 8. SWT028C - 10,000 CFM (4 Compressors)

Compressors	EDB(°F)	EWB(°F)	EWT(°F)	TMBH	SMBH	LDB	LWB	GPM
(4) 6HP	75	62	75	314.6	261.7	51.0	50.8	74
			85	304.2	257.1	51.4	51.2	73
			95	293.7	252.5	51.8	51.6	73
	80	67	75	339.2	258.0	56.3	56.2	79
			85	328.3	253.8	56.7	56.6	79
			95	317.0	249.4	57.1	57.0	78
	85	72	75	366.3	253.9	61.7	61.6	85
			85	354.4	249.8	62.1	61.9	84
			95	342.4	245.6	62.5	62.3	83

Table 9. SWT028C - 10,000 CFM (3/1 Compressors)

Compressors	EDB(°F)	EWB(°F)	EWT(°F)	TMBH	SMBH	LDB	LWB	GPM
(3) 6HP, (1) 10HP	75	62	75	364.2	283.6	49.0	48.8	87
			85	352.7	278.4	49.5	49.3	86
			95	340.5	272.9	50.0	49.8	85
	80	67	75	394.7	280.0	54.3	54.2	93
			85	382.1	274.9	54.8	54.7	92
			95	368.9	269.5	55.3	55.1	91
	85	72	75	427.8	275.5	59.7	59.6	100
			85	414.1	270.6	60.2	60.1	99
			95	399.8	265.5	60.6	60.5	97

## SWT035C - 12,000 CFM

Table 10. SWT035C - 12,000 CFM (2/2 Compressors)

Compressors	EDB(°F)	EWB(°F)	EWT(°F)	TMBH	SMBH	LDB	LWB	GPM
(2) 6HP, (2) 10HP	75	62	75	422.1	333.7	49.5	49.3	100
			85	408.7	327.6	50.0	49.8	100
			95	394.7	321.4	50.4	50.3	99
	80	67	75	457.8	329.6	54.8	54.7	108
			85	443.3	323.8	55.3	55.1	107
			95	428.0	317.7	55.7	55.6	105
	85	72	75	496.5	324.6	60.2	60.1	116
			85	481.0	319.1	60.6	60.5	114
			95	464.3	313.2	61.1	60.9	113

Table 11. SWT035C - 12,000 (1/3 Compressors)

Compressors	EDB(°F)	EWB(°F)	EWT(°F)	TMBH	SMBH	LDB	LWB	GPM
(1) 6HP, (3) 10HP	75	62	75	468.6	354.8	47.9	47.8	112
			85	454.0	348.0	48.4	48.3	111
			95	438.6	341.0	48.9	48.8	110
	80	67	75	509.4	350.7	53.2	53.1	120
			85	493.5	344.1	53.7	53.6	119
			95	476.6	337.2	54.2	54.1	118
	85	72	75	553.9	345.6	58.6	58.5	130
			85	536.7	339.2	59.1	59.0	128
			95	518.3	332.5	59.6	59.5	127

**Note:** See Table 5 DX Cooling Capacity Correction Factors on page 26 for determining unit capacity at other than nominal cfm. For a computer generated job specific selection, contact your local McQuay sales representative. For 50 Hz applications, the total capacity must be derated by 0.89 and the sensible capacity must be derated by 0.94. All capacities are gross and do not account for fan motor heat. Altitude and/or Glycol selections also available.

# Performance Data

## SWT040C - 14,000 CFM

Table 12. SWT040C - 14,000 CFM 2/2 Compressors)

Compressors	EDB(°F)	EWB(°F)	EWT(°F)	TMBH	SMBH	LDB	LWB	GPM
(2)6HP, (2)10HP	75	62	75	436.1	364.0	51.2	50.9	103
			85	422.2	357.8	51.6	51.3	102
			95	407.6	351.3	52.0	51.7	101
	80	67	75	471.8	359.6	56.4	56.3	110
			85	456.9	353.8	56.8	56.6	109
			95	440.8	347.5	57.2	57.0	108
	85	72	75	511.4	354.6	61.8	61.6	119
			85	495.0	348.9	62.1	62.0	117
			95	477.2	342.8	62.5	62.4	116

Table 13. SWT040C - 14,000 CFM 1/3 Compressors)

Compressors	EDB	EWB	EWT	TMBH	SMBH	LDB	LWB	GPM
(1)6HP, (3)10HP	75	62	75	487.9	387.0	49.6	49.5	116
			85	472.2	379.9	50.1	50.0	114
			95	456.0	372.5	50.6	50.4	113
	80	67	75	530.1	382.9	54.9	54.8	124
			85	512.8	375.9	55.4	55.3	123
			95	494.6	368.6	55.8	55.7	121
	85	72	75	576.9	377.8	60.2	60.2	134
			85	557.8	371.0	60.7	60.6	132
			95	537.7	363.9	61.2	61.1	130

**Waterside Economizer Capacity**

**SWT018D - 6000 CFM**

Table 14. SWT018D - 6000 CFM

EWT	GPM	EDB	EWB	TMBH	SMBH	LDB	LWB	LWT
45	33	75	62	120.1	118.4	57.0	55.1	52.3
	43			136.0	128.6	55.4	54.2	51.4
	72			163.5	142.7	53.3	52.5	49.5
	39	80	67	164.7	135.9	59.3	58.4	53.4
	51			187.4	145.3	57.8	57.1	52.4
	85			225.2	160.8	55.5	54.9	50.3
55	20	75	62	61.1	61.1	65.7	58.6	61.2
	26			74.2	74.2	63.7	57.8	60.7
	46			92.7	92.7	60.9	56.8	59.0
	26	80	67	93.2	93.2	65.8	62.3	62.1
	34			106.0	105.9	63.9	61.6	61.2
	59			126.2	120.0	61.7	60.5	59.3

Note: See Table 6. Waterside Economizer Capacity Correction Factors on page 26 for determining capacity at other than nominal cfm.

**SWT023D - 8000 CFM**

Table 15. SWT023D - 8000 CFM

EWT	GPM	EDB	EWB	TMBH	SMBH	LDB	LWB	LWT
45	44	75	62	160.2	157.8	57.0	55.1	52.3
	57			180.9	171.1	55.4	54.2	51.4
	96			216.9	189.6	53.3	52.5	49.5
	52	80	67	219.3	180.9	59.3	58.4	53.4
	68			249.1	193.3	57.9	57.2	52.4
	113			298.6	213.5	55.6	55.0	50.3
55	26	75	62	81.9	81.9	65.6	58.6	61.3
	35			99.1	99.1	63.7	57.8	60.7
	61			123.2	123.2	60.9	56.8	59.0
	35	80	67	124.3	124.3	65.8	62.3	62.1
	46			141.0	141.0	63.9	61.6	61.2
	79			167.5	159.5	61.8	60.6	59.3

Note: See Table 6. Waterside Economizer Capacity Correction Factors on page 26 for determining capacity at other than nominal cfm.

**SWT028D - 10,000 CFM**

Table 16. SWT028D - 10,000 CFM

EWT	GPM	EDB	EWB	TMBH	SMBH	LDB	LWB	LWT
45	55	75	62	199.9	196.6	57.0	55.2	52.3
	71			224.4	212.3	55.6	54.3	51.3
	120			266.5	234.2	53.6	52.7	49.4
	65	80	67	272.7	224.9	59.4	58.5	53.3
	85			307.9	239.6	58.1	57.3	52.3
	142			366.1	263.5	55.9	55.2	50.2
55	33	75	62	103.5	103.5	65.5	58.5	61.3
	44			123.9	123.9	63.7	57.8	60.7
	76			152.3	152.3	61.1	56.8	59.0
	44	80	67	155.4	155.4	65.8	62.3	62.1
	57			175.1	175.1	64.0	61.7	61.1
	98			206.1	197.1	62.0	60.7	59.2

Note: See Table 6. Waterside Economizer Capacity Correction Factors on page 26 for determining capacity at other than nominal cfm.

# Performance Data

## SWT035D - 12,000 CFM

Table 17. SWT035D - 12,000 CFM

EWT	GPM	EDB	EWB	TMBH	SMBH	LDB	LWB	LWT
45	65	75	62	259.8	249.5	56.0	54.6	52.9
	85			289.9	266.5	54.7	53.6	51.8
	144			338.3	290.5	52.9	52.1	49.7
	79	80	67	357.0	283.0	58.4	57.7	54.1
	101			399.8	300.7	57.1	56.4	52.9
	170			466.0	327.9	55.0	54.4	50.5
55	39	75	62	137.0	137.0	64.6	58.2	62.0
	52			160.6	160.6	62.8	57.5	61.1
	92			192.2	192.2	60.4	56.6	59.2
	52	80	67	201.8	201.9	64.6	61.9	62.7
	69			223.9	221.9	63.1	61.3	61.5
	118			261.2	244.9	61.4	60.3	59.4

Note: See Table 6. Waterside Economizer Capacity Correction Factors on page 26 for determining capacity at other than nominal cfm.

## SWT040D - 14,000 CFM

Table 18. SWT040D - 14,000 CFM

EWT	GPM	EDB	EWB	TMBH	SMBH	LDB	LWB	LWT
45	76	75	62	303.4	291.4	56.0	54.6	53.0
	99			339.0	311.5	54.7	53.6	51.8
	168			396.3	339.9	52.8	52.1	49.7
	92	80	67	417.3	330.7	58.4	57.6	54.1
	118			467.6	351.4	57.0	56.4	52.9
	198			545.9	383.6	54.9	54.4	50.5
55	46	75	62	159.6	159.6	64.6	58.2	62.0
	61			187.4	187.4	62.8	57.5	61.1
	107			224.9	224.9	60.3	56.6	59.2
	61	80	67	235.6	235.6	64.6	61.9	62.7
	80			261.7	259.3	63.1	61.3	61.5
	137			305.9	285.7	61.3	60.3	59.5

Note: See Table 6. Waterside Economizer Capacity Correction Factors on page 26 for determining capacity at other than nominal cfm.

**Heating Capacity Data**

**Hot Water Coil Capacity (1 Row)**

Table 19. Entering Water 180°F and Entering Air 60°F

UNIT	CFM	TMBH	LWT	LDB	GPM
018C	4000	191.6	158.1	103.8	18
	7000	241.7	152.4	91.6	18
023C	6000	277.9	158.8	102.4	25
	9000	329.7	154.9	93.5	25
028C	8000	353.3	159.8	100.4	35
	10500	397.1	157.5	94.6	35
035C	9000	430.2	158.1	103.7	40
	13500	512.3	154.0	94.7	40
040C	11000	524.5	158.2	103.6	50
	16000	621.0	155.2	95.5	50

Note: For complete one-row capacity and extended two-row capacity, please contact your McQuay sales representative. Selections based on water, for glycol/water solutions, please contact your McQuay sales representative.

**Electric Heat**

Table 20. SWT018D - 040D

SWT	208V/60HZ/3PH			230V/60HZ/3PH			400V/50HZ/3PH			460V/60HZ/3PH			575V/60HZ/3PH		
Unit Size	kW	MBH	FLA	kW	MBH	FLA	kW	MBH	FLA	kW	MBH	FLA	kW	MBH	FLA
018D - 040D	27.8	94	77.2	34	116	85.6	25.7	88	37.2	34	116	42.8	34	116	34.2

**Component Pressure Drops**

Table 21. Unit Air Pressure Drops (inches w.g.)

Unit	CFM	4", 30% Filter	4", 65% Filter	4-Row Econo.	6-Row DX	1-Row HW
SWT018C	4500	0.14	0.27	0.28	0.52	0.11
	5000	0.17	0.31	0.34	0.61	0.13
	6000	0.23	0.41	0.46	0.81	0.17
	7000	0.29	0.52	0.60	1.04	0.22
SWT023C	6000	0.15	0.28	0.29	0.54	0.10
	7000	0.19	0.35	0.38	0.69	0.13
	8000	0.23	0.43	0.48	0.85	0.16
	9000	0.28	0.51	0.59	1.03	0.20
SWT028C	8000	0.17	0.31	0.34	0.61	0.11
	9000	0.20	0.37	0.41	0.74	0.13
	10000	0.24	0.44	0.49	0.86	0.16
	11000	0.28	0.50	0.58	1.00	0.19
SWT035C	8000	0.12	0.23	0.23	0.44	0.08
	10000	0.17	0.32	0.34	0.62	0.11
	12000	0.23	0.42	0.47	0.83	0.15
	14000	0.29	0.52	0.61	1.04	0.19
SWT040C	10000	0.14	0.27	0.28	0.52	0.08
	12000	0.19	0.35	0.38	0.68	0.11
	14000	0.24	0.44	0.50	0.86	0.15
	16000	0.30	0.55	0.63	1.05	0.19

Note: DX pressure drops are wet coil and economizer are dry coil. All units must have a DX coil pressure drop.

# Performance Data

Figure 17. Condenser Water Pressure Drop, SWT 018C through SWT 040C

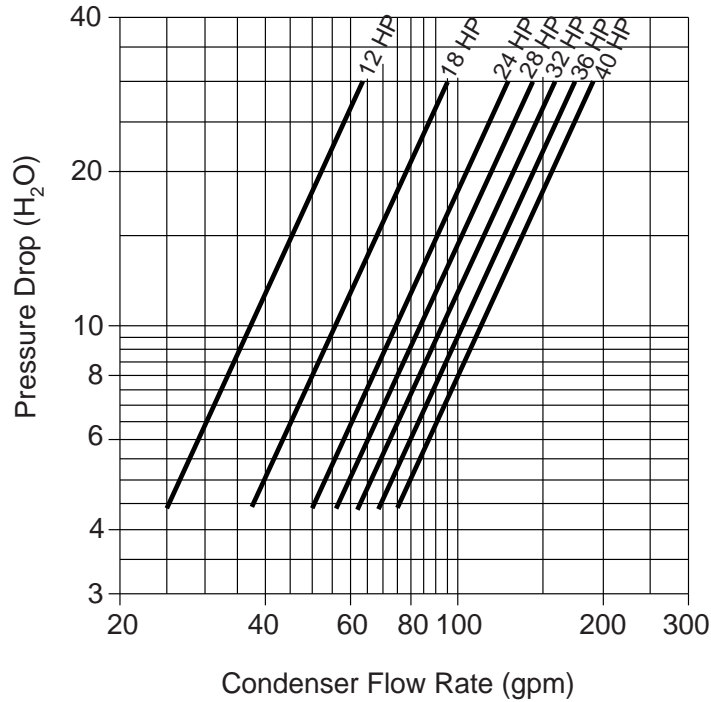

Note: HP = Total unit compressor horsepower.

Figure 18. Economizer System Water Pressure Drop, SWT 018C through 040C

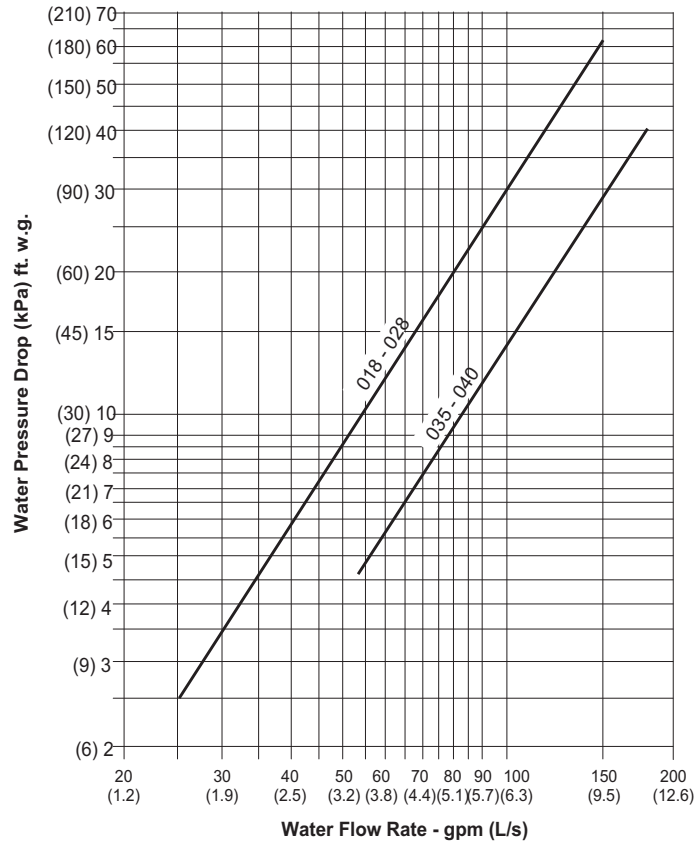

Note: Includes coil, Control valves, and interconnecting piping.  
 Note: Add this ΔP to condenser ΔP to obtain unit ΔP for pump selection.

Figure 19. Hot Water Coil Water Pressure Drop (1-row), SWT018C through SWT040C

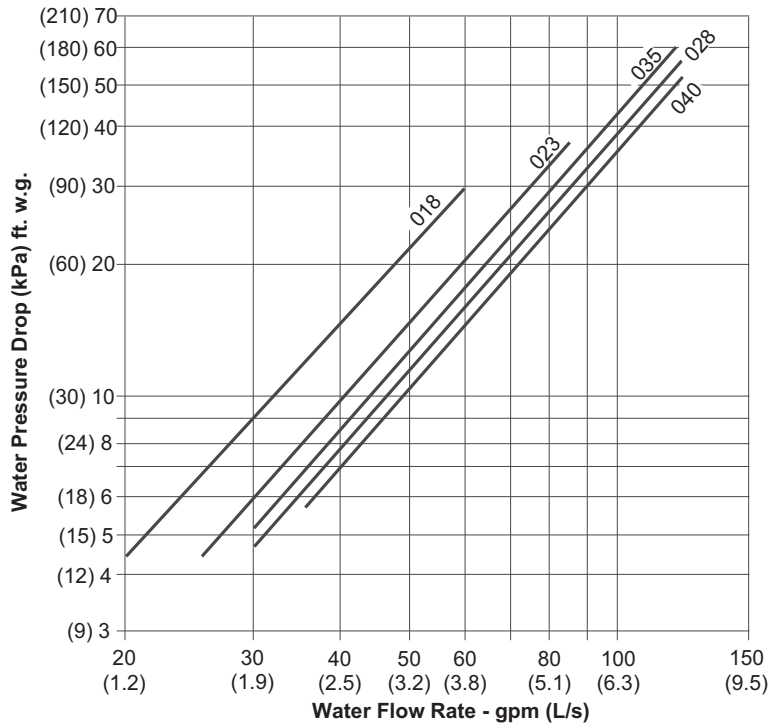

Note: Includes coil, control valve and interconnecting piping.

Figure 20. Water Regulating Valve Pressure Drop

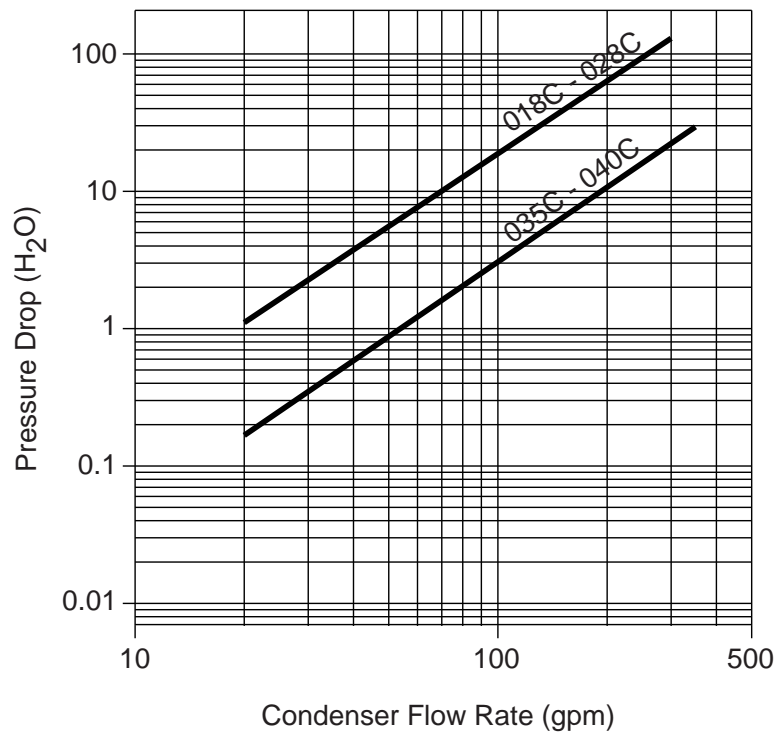

# Performance Data

## Fan Curves

Figure 21. SWT018C, 15"x15" Fan Without Variable Inlet Vanes

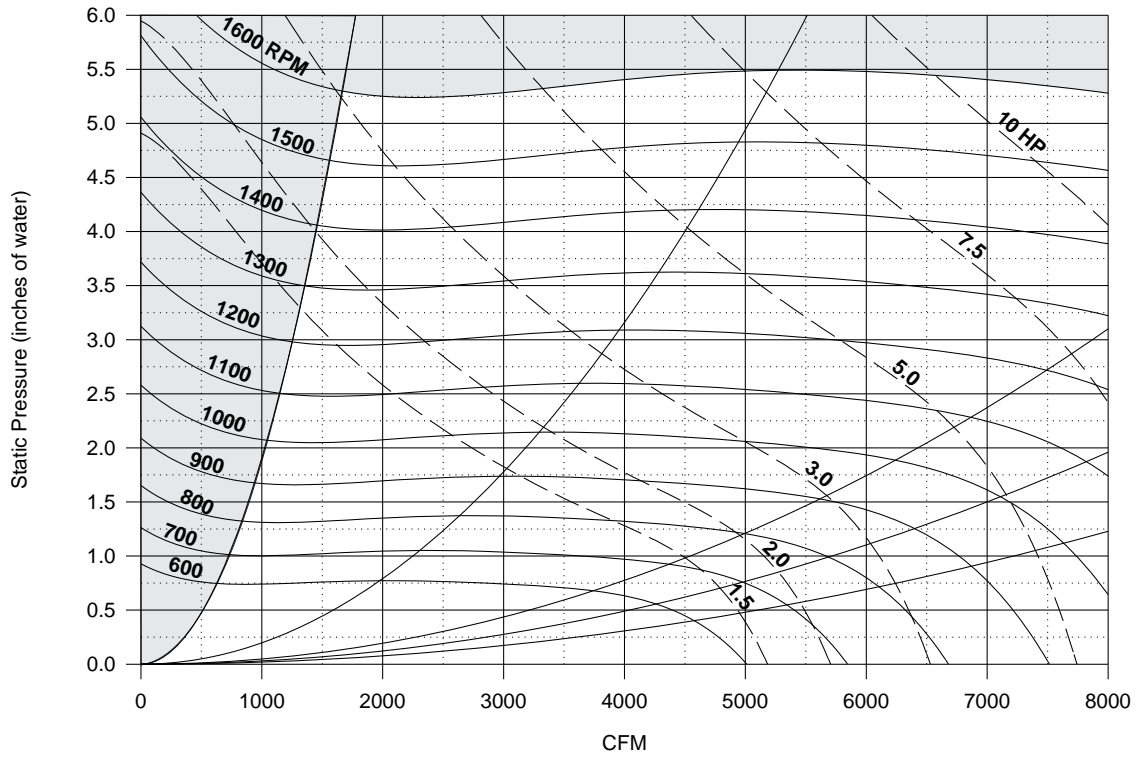

Note: Fan TSP limit is 5.5" of water. Consult your local McQuay sales representative for applications beyond this range.

Figure 22. SWT018C, 15"x15" Fan, with Variable Inlet Vanes

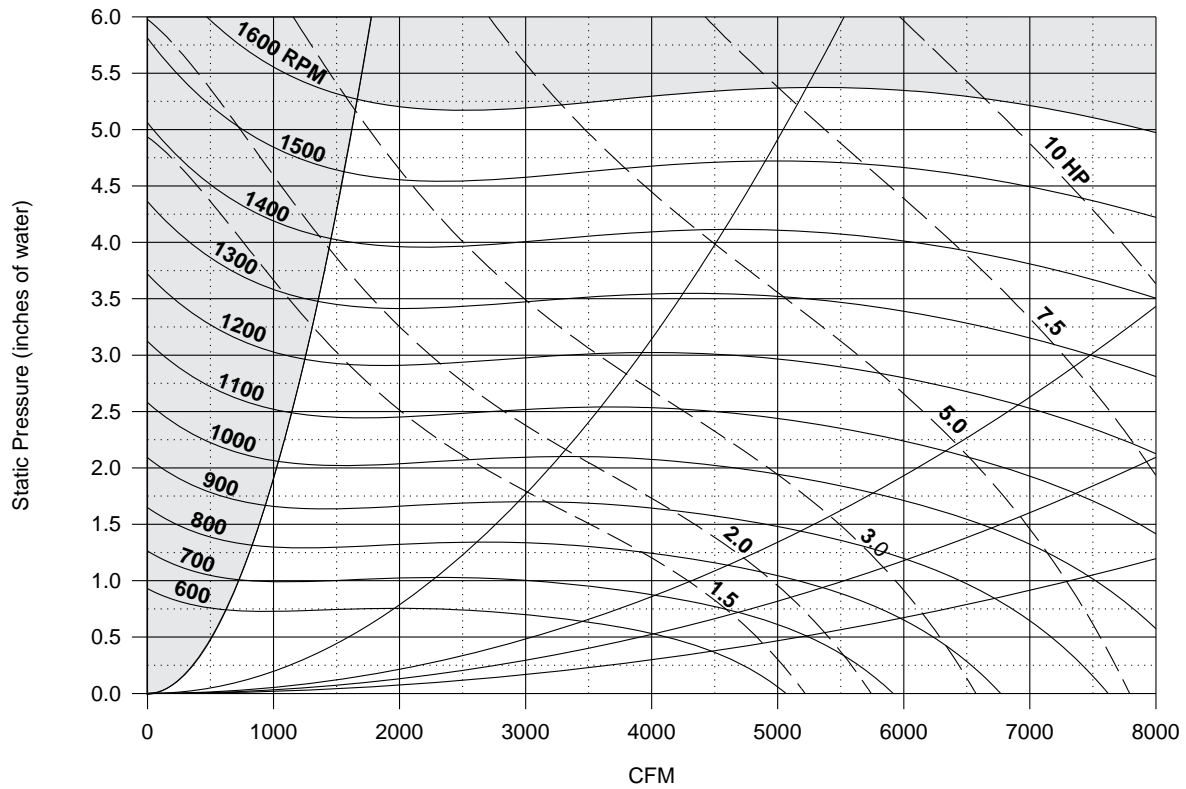
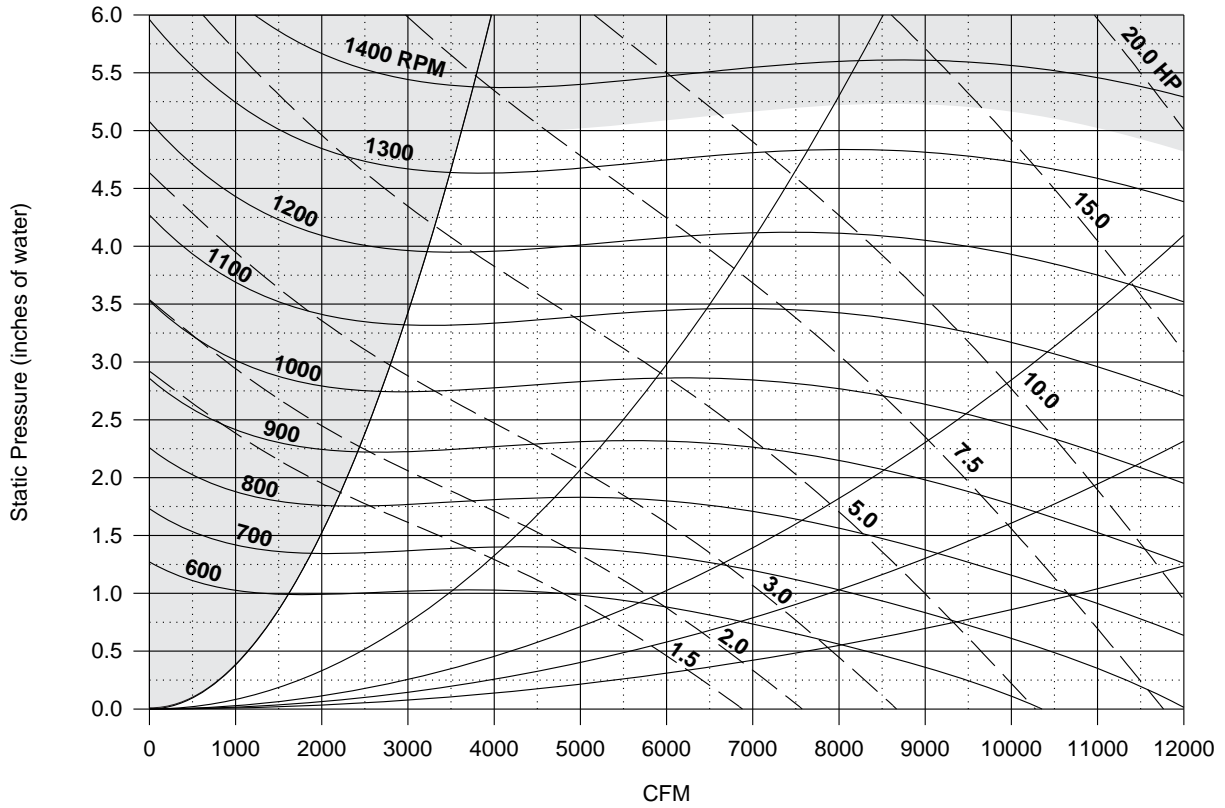
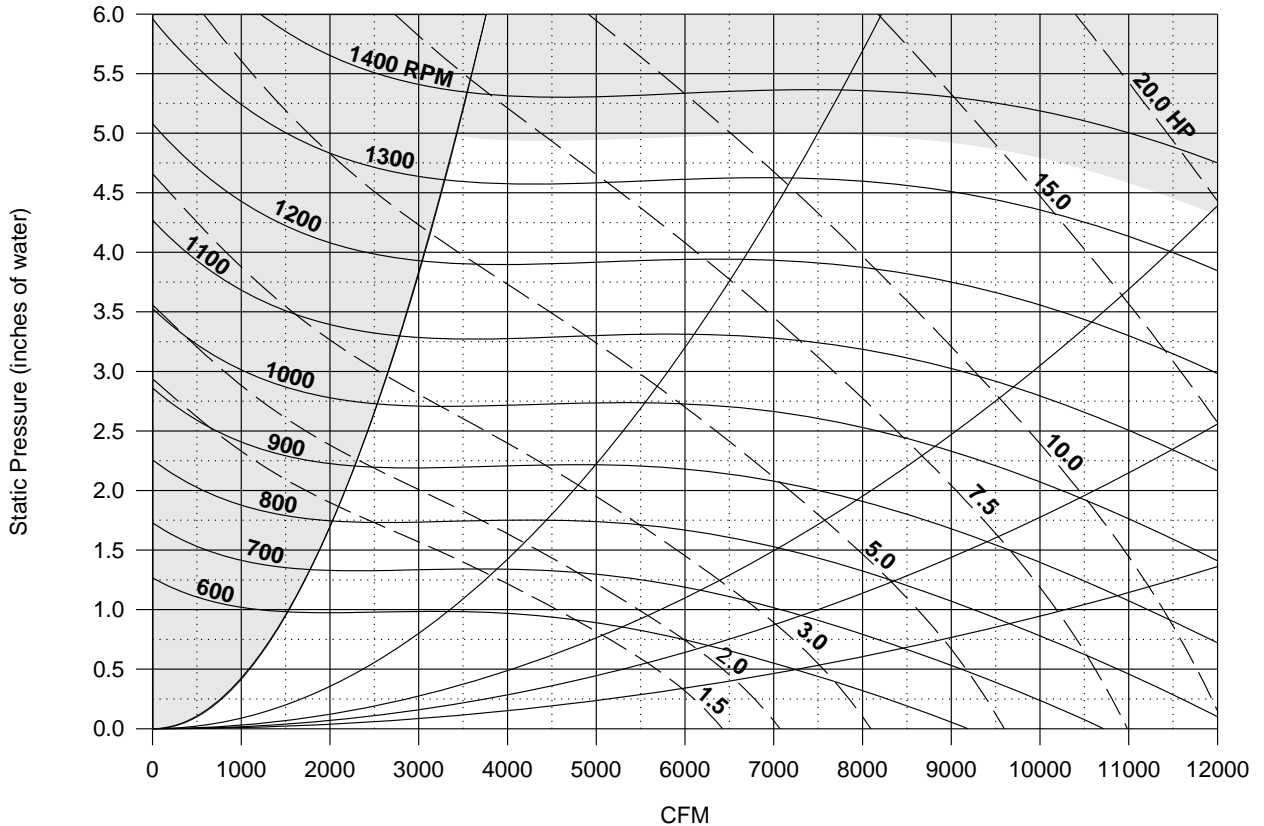

Figure 23. SWT023C/028C, 18"x18" Fan, without Variable Inlet Vanes



Note: Fan TSP limit is 5.5" of water. Consult your local McQuay sales representative for applications beyond this range.

Figure 24. SWT023C/028C. 18"x18" Fan with Variable Inlet Vanes



# Performance Data

Figure 25. SWT 035C/040C. Dual 15"x15" Fan, Without Variable Inlet Vanes

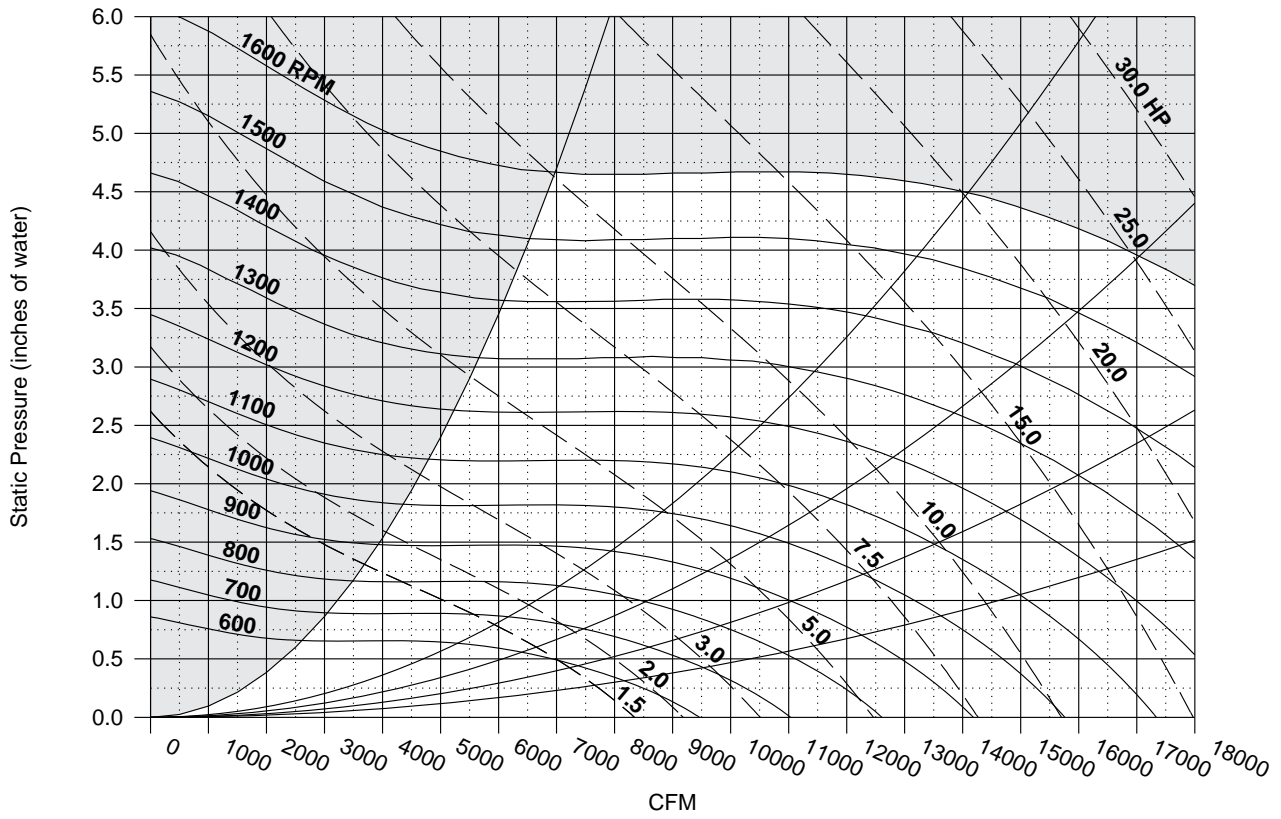

**Note:** Fan TSP limit is 5.5" of water. Consult your local McQuay sales representative for applications beyond this range.

Figure 26. Left Side, Front (CW) Discharge

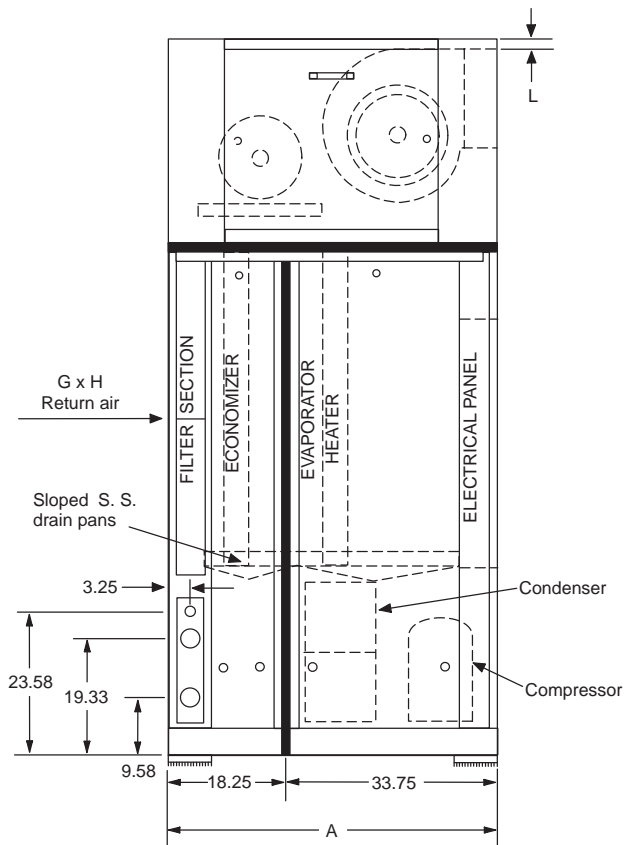
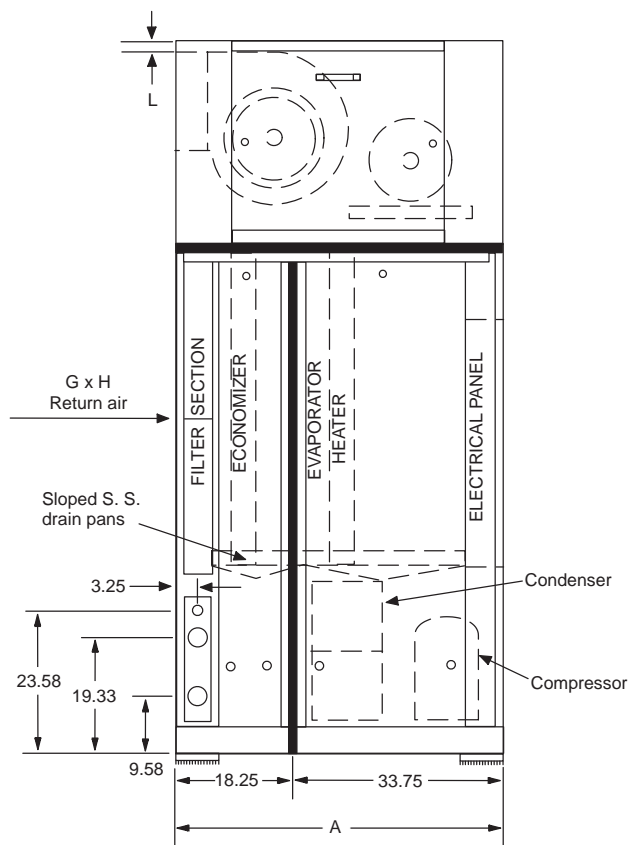

Figure 27. Left Side, Back (CCW) Discharge



**Note:** Select unit arrangement on the unit selection.

Table 22. SWT018C - 040C Dimensions

BASIC UNIT		018C	023C	028C	035C	040C
A	Depth <sup>a b</sup>	52.00	52.00	52.00	52.00	52.00
B	Length <sup>a b</sup>	84.00	84.00	84.00	100.00	100.00
C	Height <sup>a b</sup>	112.75	112.75	112.75	112.75	112.75
D	Fan Discharge	18.62	21.88	21.88	18.62	18.62
E	Fan Discharge	15.88	18.88	18.88	15.88	15.88
F	Unit Side to Fan	32.69	31.06	31.06	23.88	23.88
G	Return Duct Height	45.94	45.94	45.94	45.94	45.94
H	Return Duct Length	80.00	80.00	80.00	96.00	96.00
J	Water Out/In (ODS)	2-1/8	2-1/8	2-1/8	2-5/8	2-5/8
K	Hot Water Out/In (ODS)	1-5/8	1-5/8	1-5/8	1-5/8	1-5/8
L	To Fan Discharge	2.0	2.0	2.0	6.46	6.46

a. Dimensions do not include lifting lugs, handle, latch, or fastener extensions.  
 b. For shipping dimensions add 4" (102mm) to depth, 8" (204mm) to length, and 4" (102mm) to height.

# Dimensional Data

Figure 28. Unit Front Plan and Front Elevation

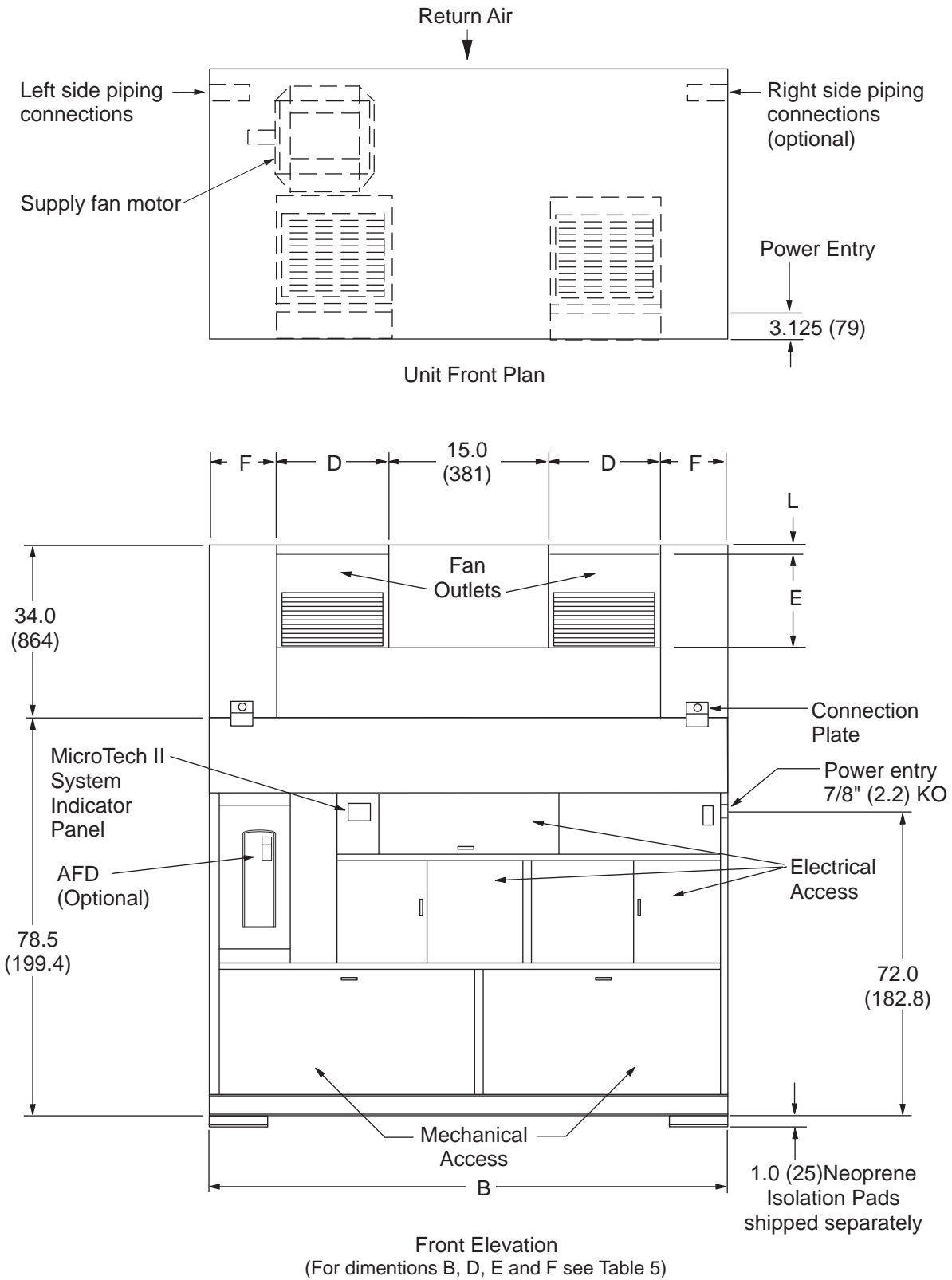

- Note:**
1. See Table 25 for dimensions B, D, E, F and L.
  2. Service connections determined when facing the front of the unit. Left-hand standard, right-hand optional. Please indicate on the unit submittal.
  3. Unit sizes 018C, 023C, and 028C have single fan.
  4. Unit sizes 018C, 023C, and 028C have single mechanical access panel in bottom front and bottom back.

Figure 29. Back Elevation and Left Side (typical SWT018C - 040C)

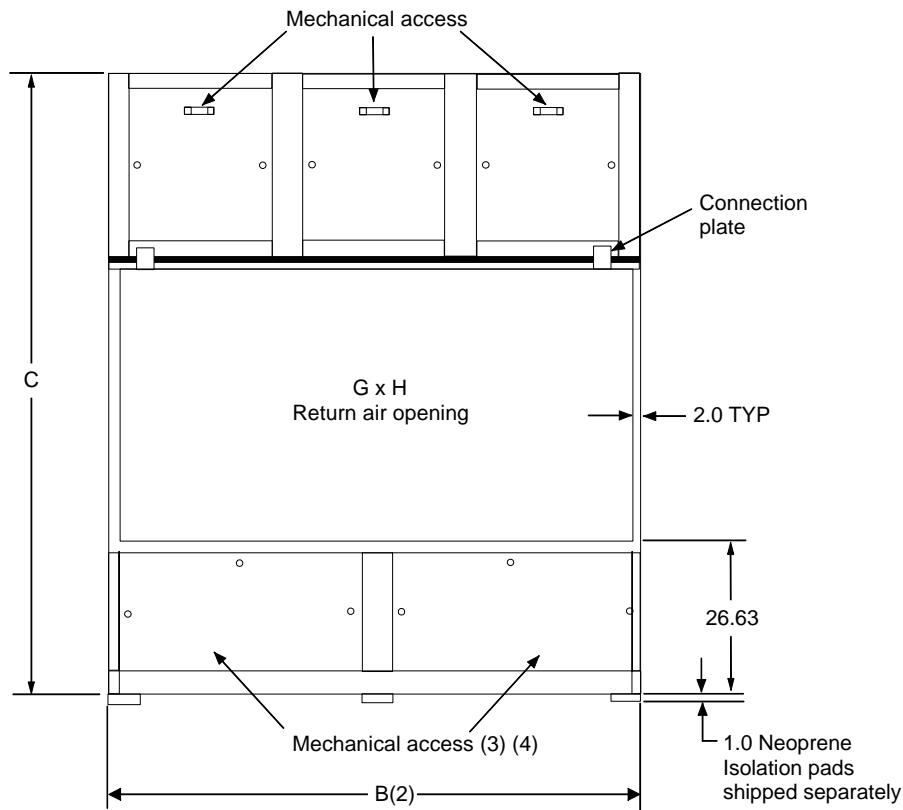

Back Elevation

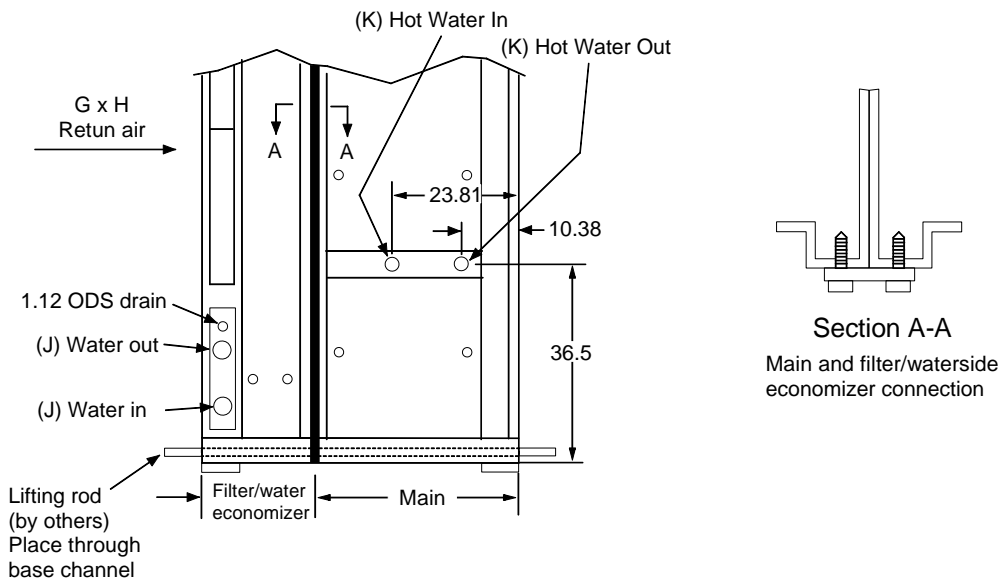

Left Elevation

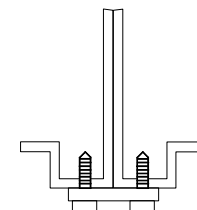

Section A-A  
Main and filter/waterside economizer connection

- Note:**
1. Filters are removable from the rear of the unit or through a side filter access door, located on piping connection side.
  2. Length will be increased by approximately 3-1/2", for piping connections when water economizer option is ordered
  3. Mechanical access panel(s) in the back of the unit start 2" below return duct opening. Do not obstruct the access panel(s).
  4. There are two access doors on 018C, 023C, and 028C instead of three as shown.
  5. All dimensions are given in inches.
  6. All dimensions are  $\pm 0.25"$ .

**Note:**

**Note:**

# Electrical Data

Table 23. SAF Motor Nameplate Amp Table

Horsepower	TYPE	208/60/3	230/60/3	400/50/3 <sup>a</sup>	460/60/3	575/60/3
		FLA	FLA	FLA	FLA	FLA
3	High Efficiency	9.9	9.0	4.5	4.5	3.4
	Premium Efficiency	9.3	8.2	4.1	4.1	3.1
5	High Efficiency	16.1	14.0	7.0	7.0	5.3
	Premium Efficiency	15.7	13.6	6.8	6.8	5.2
7.5	High Efficiency	25.0	21.6	10.8	10.8	8.2
	Premium Efficiency	22.3	20.0	10.0	10.0	7.4
10	High Efficiency	33.0	28.0	14.0	14.0	11.0
	Premium Efficiency	29.0	25.8	12.9	12.9	10.3
15	High Efficiency	44.8	40.6	20.3	20.3	16.2
	Premium Efficiency	43.4	37.8	18.9	18.9	14.1
20	High Efficiency	61.0	50.0	25.0	25.0	20.0
	Premium Efficiency	57.0	49.0	24.5	24.5	18.9
25	High Efficiency	74.0	62.0	31.0	31.0	24.3
	Premium Efficiency	70.0	61.0	30.5	30.5	24.2

a. 460/60/3 motors are used. Derate nameplate horsepower to 0.83 to obtain actual horsepower.

Table 24. Compressor Amperages

Compressor HP	Refrigerant	208/60/3		230/60/3		460/60/3		575/60/3	
		RLA	LRA	RLA	LRA	RLA	LRA	RLA	LRA
6	R-407C	16.3	173.0	14.7	156.0	7.3	75.0	5.9	54.0
10	R-407C	30.1	239.0	27.2	216.0	13.6	125.0	10.9	80.0

Table 25. Electric Heat

SWT UNIT SIZE	208V/60HZ/3PH			230V/60HZ/3PH			400V/50HZ/3PH			460V/60HZ/3PH			575V/60HZ/3PH		
	kW	MBH	FLA	kW	MBH	FLA	kW	MBH	FLA	kW	MBH	FLA	kW	MBH	FLA
018C - 040C	27.8	94	77.2	34	116	85.6	25.7	88	37.2	34	116	42.8	34	116	34.2

## Supply Power Wiring

1. Units require three-phase power supply.
2. Allowable voltage tolerances:
  - a. 60 Hertz
    - i. Nameplate 208V: Min. 187V, Max. 229V
    - ii. Nameplate 230V: Min. 207V, Max. 253V
    - iii. Nameplate 460V: Min. 414V, Max. 506V
    - iv. Nameplate 575V: Min. 518V, Max. 632
  - b. 50 Hertz
    - i. Nameplate 400V: Min. 342V, Max. 418V
3. Power lead wire sizing:
  - a. For units with cooling capability (all concurrent loads) with or without hot water heating and circuits with motor loads only:  
 $MCA = 1.25$  (largest motor RLA or FLA) + other loads + 2 amps
  - b. For units with cooling capability and non concurrent electric heat capability:  
 In the cooling mode, the loads will be composed of supply fan motor and compressors. In heating mode, the loads will be composed of supply fan motor and electric heater. The MCA is calculated for unit running in either mode; the highest value obtained is used for the MCA.
    - i. For unit in cooling mode:  
 $MCA = 1.25$  (largest RLA or FLA) + other loads + 2 amps
    - ii. For unit in heating mode:  
 $MCA = 1.25$  (electric heat FLA + supply fan motor FLA) + 2 amps

**Note:** Use copper wire only.

4. Size wires in accordance with Table 310-16 or 310-19 of the National Electrical Code.
5. Wires should be sized for a maximum of 3% voltage drop. See Table 27 and Table 28 for Single Disconnect or Power Block lug sizes.

*Table 26. Single Disconnect*

UNIT	VOLTAGE	SIZE (AMPS)
018-028	208/230	225
018-028	400/460	100
018-028	575	100
035-040	208/230	225
035-040	400/460	150
035	575	100
040	575	150

*Table 27. Lug Sizes For Single Disconnect*

DISCONNECT SIZE	LUG SIZE
100	#6-2/0
150	#2-3/0
225	#3-300 MCM
250	#4-350 MCM

*Table 28. Lug Sizes For Power Block*

UNIT	VOLTAGE	LUG SIZE
018-040	ALL	#6-400 MCM

# Unit Weights

Table 29. Unit and Component Weights in lbs.

Unit Weights	Unit Size					
		018C	023C	028C	035C	040C
<b>Basic Configuration</b>						
SWT basic unit		1314	1314	1314	1473	1473
<b>Filters</b>						
4" - 30% efficiency		(Included in basic unit weight)				
4" - 65% efficiency		(Included in basic unit weight)				
<b>Evaporator Coil</b>						
6 Row, 12 fpi		250	294	347	417	450
4 Row, 12 fpi		206	238	278	333	354
<b>Water Economizer Coil (1)</b>						
4 Row, 12 fpi		266	298	340	393	410
Water weight		51	65	75	94	111
<b>Hot Water Coil (2)</b>						
1 Row, 12 fpi		71	97	119	130	152
Water weight		16	20	23	28	32
<b>Electric Heat</b>						
34 KW		20	20	20	20	20
<b>Compressor / Condenser Assembly</b>						
	<b>Water</b>					
(4) 6	43	856	856	856	856	—
(3) 6 (1)10	57	—	987	987	987	987
(2) 6 (2)10	66	—	—	1105	1105	1105
(1) 6 (3)10	74	—	—	—	1233	1233
(4)10	95	—	—	—	1368	1368
<b>Supply Fan (3)</b>						
15"x15" FC		900	—	—	—	—
18"x18" FC		—	930	930	—	—
(2) 15"x15" FC		—	—	—	1120	1120
<b>Supply Fan Motors</b>						
3 HP ODP		71	—	—	—	—
5 HP ODP		82	—	—	—	—
7.5 HP ODP		124	124	—	—	—
10 HP ODP		144	144	144	144	—
15 HP ODP		—	185	185	185	185
20 HP ODP		—	—	214	214	214
25 HP ODP		—	—	—	—	266
3 HP TEFC		72	—	—	—	—
5 HP TEFC		85	—	—	—	—
7.5 HP TEFC		140	140	—	—	—
10 HP TEFC		170	170	170	170	—
15 HP TEFC		—	235	235	235	235
20 HP TEFC		—	—	300	300	300
25 HP TEFC		—	—	—	—	330
<b>Variable Frequency Drive 208/230V</b>						
3 HP		25	—	—	—	—
5 HP		25	—	—	—	—
7.5 HP		40	40	—	—	—
10 HP		50	50	50	50	—
15 HP		—	50	50	50	50
20 HP		—	—	75	75	75
25 HP		—	—	—	—	75
<b>Variable Frequency Drive 380/460V</b>						
3 HP		20	—	—	—	—
5 HP		20	—	—	—	—
7.5 HP		25	25	—	—	—
10 HP		25	25	25	25	—
15 HP		—	40	40	40	40
20 HP		—	—	50	50	50
25 HP		—	—	—	50	50

**Note:** Notes: 1. Water economizer coil weight includes valves and piping.  
 2. Hot water coil weight includes valves and piping.  
 3. Supply fan weight does not include motor or VFD.

## General

Furnish and install, as shown on plans, McQuay model SWT self-contained packaged air conditioning system(s). Unit performance, electrical characteristics and unit arrangement shall be per the job schedule.

[Each unit shall be completely factory assembled and shipped in one piece.] [Each unit shall be shipped in two pieces, a base unit section and the unit fan section.] All units shall be shipped with a full charge of Refrigerant 22 or 407C and oil. Unit ratings shall be in accordance with the latest update of ARI Standard 360.

All units shall have decals and tags to indicate caution areas and to aid in unit service. A unit nameplate shall be fixed to a permanent panel next to the main control panel access. Electrical wiring diagrams shall be supplied with each unit. Installation, operating and maintenance bulletins and start-up forms shall be supplied with each unit.

## Factory Run Test

Each unit shall undergo a rigorous factory run test prior to shipment and factory test sheets shall be available upon request. The factory test shall include dynamic trim balancing of the completed fan assembly, a compressor run check, a complete run test of all electrical components and safeties, including proper control sequencing, a leak check of all refrigerant circuits, a leak check of all water circuits and a final unit inspection.

## Safety Agency Listed

The complete unit(s) shall be ETL-US and ETL-Canada listed by Intertek Testing Services, Inc. Units shall conform to bi-national standard ANSI/UL Standard 1995/CSA Standard C22.2 No. 236. Unit(s) shall be accepted for use in the City of New York by the Department of Building, MEA #368-93-E Vol. II.

## Cabinet, Casing and Frame

Each unit shall have a welded 3/16" structural steel base integrated with formed members of 10, 12 and 14 gauge continuous galvanized steel. Exterior frame and panels shall be constructed of pre-painted galvanized steel for aesthetics and long term durability. Paint finish to include a base primer with a high quality, polyester resin topcoat of a neutral beige color. Finished surface to withstand a minimum 750-hour salt spray test in accordance with ASTM B117 standard for salt spray resistance. Lifting brackets capable of handling the unit shipping weight shall be welded to the unit base with holes to accept cable or chain hooks.

Each unit shall be compartmentalized for ease of service and shall be designed to permit adjustment of system electrical and refrigeration components while the unit is in operation. The unit shall incorporate removable access panels tightly set on neoprene gaskets. Access panels shall be a minimum of 18-gauge galvanized steel and shall be located on all sides of the unit for complete accessibility. The airside cabinet shall be insulated with 1", 1.5 pound density coated glass fiber insulation. [Solid galvanized steel liners shall be provided, allowing no exposed insulation within the air stream.]

The unit shall be comprised of three distinct sections: 1) Main cooling/heating, 2) Filter/waterside economizer and 3) Fan section. Each unit shall be designed for disassembly into the three distinct sections for access to the mechanical equipment room. Disassembly of the unit shall not require the breaking of any refrigeration lines. Separation of water piping shall be through the

use of factory installed grooved couplings. The maximum allowable section width, including fastener heads, shall not exceed 34.5 inches.

## Filter/Economizer Section:

### Filters

Each unit shall be provided with an integral filter section complete with 4" panel filters. The filters shall be removable from the rear of the unit and shall have side access capability through [access panels] [hinged and latched access doors] on each end of the unit. The use of 2" filters is not acceptable.

[4" thick, 30% efficient, UL Std. 900, Class II, AmericanAirFilter filters shall be provided. Filters shall be frame mounted and shall slide into galvanized steel tracks contained within the unit.]

[4" thick, 60-65% efficient, UL Std. 900, Class II, AmericanAirFilter Varicel filters shall be provided. Filters shall be frame mounted and shall slide into galvanized steel tracks contained within the unit.] [An auxiliary pre-filter rack, with 2" thick 30% efficient filters, shall be provided to upstream of the high efficiency filters.]

[4" thick, 80-85% efficient, UL Std. 900, Class II, AmericanAirFilter Varicel filters shall be provided. Filters shall be frame mounted and shall slide into galvanized steel tracks contained within the unit.] [An auxiliary pre-filter rack, with 2" thick 30% efficient filters, shall be provided to upstream of the high efficiency filters.]

### Waterside Economizer

A complete waterside economizer package shall be provided including a mechanically cleanable [chemically cleanable] coil, control valves and factory piping complete with cleanouts. Coils shall be fabricated of seamless 1/2" diameter copper tubing that is mechanically expanded into high efficiency aluminum plate fins. Coils shall be a minimum 4-row, staggered tube design with 12 fins per inch. The complete economizer package shall be rated for 400psig waterside working pressure.

The economizer section shall be complete with an insulated stainless steel drain pan. The drain pan shall be sloped in two directions to provide positive drainage. Access panels on both sides of the unit shall provide convenient access to the coil, valves and drain pan for inspection and cleaning. A factory installed drain line, with trap and cleanout, shall be provided for convenient connection at the unit exterior.

Economizer operation shall be controlled to maximize free cooling. Economizer operation shall be enabled whenever the entering water temperature is less than the entering air temperature by a field adjustable value. The economizer control valve shall modulate in response to the cooling load. Control valve operation shall [maintain full flow through the unit at all times.] [isolate the unit from the condenser water loop when there is no call for cooling, allowing for the use of an energy saving, variable pumping system.]

Mechanical cooling shall be enabled during economizer operation. If the economizer control valve is driven 90% open and the cooling load is not satisfied, compressors will stage on to maintain set point. To maximize energy savings, economizer control will maintain full water flow until the differential between entering water and entering air temperatures falls below set point.

A factory installed, non-averaging type freeze-stat shall provide some protection against coil freeze-up.

The completed economizer assembly shall be factory leak tested.

## **Airside Economizer Control (External Mixing Box)**

Integrated airside economizer control capability of a separate unit or remote mounted mixing box shall be provided. Economizer operation shall be controlled to maximize free cooling operation. Economizer shall be enabled whenever the remote [outside air enthalpy sensor] [comparative enthalpy sensors] [outside air temperature sensor] indicates that outside air is suitable for free cooling. The remote economizer damper actuator shall modulate in response to the cooling load.

Mechanical cooling shall be enabled during economizer operation. If the outside air damper is driven to 90% open and the cooling load is not satisfied, compressors will stage on to maintain set point. To maximize energy savings, the economizer control will maintain 100% outdoor airflow until disabled by the enthalpy or temperature cutout. Outside air will reset to minimum position at that time.

## **Fan Section**

### **Fan Assembly**

All fan assemblies shall be statically and dynamically balanced at the factory, including a final trim balance, prior to shipment. All fan assemblies shall employ solid steel fan shafts. Heavy-duty pillow block type, self-aligning, grease lubricated ball bearings shall be used. Bearings shall be sized to provide an L-50 life at 200,000 hours and shall be no smaller than the main shaft diameter. The entire fan, drive and motor assembly shall be mounted on a welded, heavy-gauge tubular steel frame and shall be mounted on [spring isolators] [spring isolators with seismic restraints]. The fan assembly shall further be isolated from the unit with a flexible connection at the fan discharge. Fixed pitch V-belt drives with matching belts shall be provided. V-belt drives shall be selected at [the manufacturer's standard service factor] [1.5 times fan brake horsepower].

The fan assembly shall feature a gradual expansion, aerodynamic duct outlet to reduce system sound generation.

### **Fan (SWT018C-028C)**

The supply air fan shall be a double width, double inlet (DWDI) forward curved centrifugal fan, with hub and shaft secured with mating keyways. The fan wheel and housing shall be constructed from painted steel and shall be Class II construction to satisfy the specified application.

### **Fan (SWT035C & 040C)**

The supply air fan system shall be dual, double width, double inlet (DWDI) forward curved centrifugal fans, with hubs and shaft secured with mating keyways. The fan wheels and housings shall be constructed from painted steel and shall be Class II construction to satisfy the specified application.

### **Fan Motor**

Fan motors shall be heavy-duty 1800 rpm [open drip-proof (ODP)] [totally enclosed fan cooled (TEFC)] type with grease lubricated ball bearings. [Motors shall be high efficiency and meet applicable EPACT requirements.] [Motors shall be premium efficiency.] Motors shall be NEMA, T-frame, Class B. Motors shall be mounted on an adjustable base that provides for proper alignment and belt tension adjustment.

## **Variable Frequency Drives (SWT18C-040C)**

An electronic variable frequency drive shall be provided for the supply air fan. Variable frequency drives shall be latest generation pulse width modulation type utilizing IGBT technology. The drive shall be factory installed in a designated location that provides ready access to the drive and does not void unit accessibility. Drives shall meet UL Standard 95-5V and the variable frequency drive manufacturer shall have specifically approved them for plenum duty application. The completed unit assembly shall be listed by a recognized safety agency, such as ETL.

The unit manufacturer shall install all power and control wiring. A manually activated bypass contactor arrangement shall be provided. The bypass arrangement will allow fan operation at full design CFM, even if the drive has been removed for service.

The supply air fan drive output shall be controlled by the factory installed main unit control system and drive status and operating speed shall be monitored and displayed at the main unit control panel. A factory mounted, field adjustable duct high-limit control shall be provided to protect ductwork from excessive duct pressure. The installer shall provide and install sensor tubing from [a single unit mounted pressure sensor] [two unit mounted pressure sensors] to the duct location(s).

All drives shall be factory run tested prior to unit shipment.

## **Coils**

### **Drain Pan**

The main coil section shall be complete with an insulated stainless steel drain pan. The drain pan shall be sloped in two directions to provide positive drainage. Access panels on both sides of the unit shall provide convenient access to the coil and drain pan for inspection and cleaning. A factory installed drain line, with trap and cleanout, shall be provided for convenient connection at the unit exterior.

### **Cooling Coil**

Direct expansion (DX) cooling coils shall be fabricated of seamless 1/2" diameter high efficiency copper tubing that is mechanically expanded into high efficiency aluminum plate fins. Coils shall be a 6-row, staggered tube design with 12 fins per inch. All units shall have an independent refrigerant circuit per compressor and shall use a combination row/interlaced circuiting for efficient part load operation and to prevent air temperature stratification at partial load conditions. Each circuit shall be fed by an adjustable thermal expansion valve, with external equalizer, sized to provide efficient operation at full and at part load operating points. Plastic sleeves shall protect all distributor tubes.

All coils shall be factory leak tested with high pressure air under water.

### **Hot Water Coil**

A 1 row hot water heating coil shall be factory installed. Coils shall be fabricated of seamless 1/2" diameter copper tubing that is mechanically expanded into high efficiency aluminum plate fins. All coil vents and drains shall be factory installed. Access panels shall provide convenient access to the coil and valve for inspection and cleaning.

A factory installed two-way [modulating] [on/off] control valve and actuator shall provide control of the hot water coil. The valve actuator shall be controlled by the factory installed main unit control system.

[Propylene glycol shall be added to the hot water circuit to protect against coil freeze-up.]

[A factory installed, non-averaging type freeze-stat shall provide some protection against coil freeze-up.]

Coils shall be factory leak tested with high pressure air under water.

## Electric Heat

Staged electric heating coils shall be factory installed in the unit heat section. Heating coils shall be visible and easily accessed for inspection and service. Heating coils shall be constructed of low watt density, nickel-chromium elements. Equipment protection controls shall include automatic reset high limit control for each heater element with manual reset backup line break protection in each heater element branch circuit. Heating element branch circuits shall be individually fused to a maximum of 48 Amps per NEC requirements.

Multiple full magnetic line break contactors shall be controlled by the factory installed main unit control system to provide multiple stages of control.

## Condensers

Condensers shall be a counter flow, tube and tube design with all nonferrous water channels. Each condenser shall be on an independent refrigerant circuit and shall provide liquid sub-cooling for optimum system performance. Condensers shall be rated for 400psig refrigerant working pressure. Each condenser shall be suitable for 400psig waterside working pressure and shall be mechanically cleanable. All factory piping shall be capable of a waterside working pressure of 400 psig. Condensers shall be factory piped to provide for single field condenser water supply and return connections.

Units provided with condensers that are not mechanically cleanable will not be acceptable.

Condensers shall be factory leak tested with high pressure air under water. The completed condenser and interconnecting piping assembly shall be factory leak tested.

## Condenser head pressure control (Not available with Water Economizer)

Mechanical cooling shall be available whenever entering condenser water temperatures are 55°F or warmer, without the use of head pressure control. For entering condenser water temperatures below 55°F, a factory installed and controlled 2-way modulating head pressure control valve shall be provided. The valve actuator shall be controlled through the factory installed main unit control system to maintain refrigerant head pressure at entering condenser water temperatures as low as 40°F.

## Compressors

Each unit shall have multiple, heavy-duty scroll compressors. Each compressor shall be on an independent refrigerant circuit and include [suction and discharge service valves with gauge ports], sight-glass, anti-slug protection, motor overload protection and a time delay to prevent short cycling and simultaneous starting of compressors following a power failure. Compressors shall be isolated on resilient rubber isolators to decrease noise transmission. The number of compressors shall be as shown on the unit schedule.

## Refrigeration Controls

Each unit shall have multiple independent refrigeration circuits. Each circuit shall include a filter-drier, liquid moisture indicator/sight-glass, thermal expansion valve, liquid line shutoff valve with charging port and high pressure relief device. The thermal expansion valve shall be capable of modulation from 100% to 25% of its rated capacity. [Shutoff valves shall isolate each filter-drier and sight-glass. (Units with compressor service valves only.)] Sight-glasses shall be accessible for viewing without disrupting unit operation. Each circuit shall be dehydrated and factory charged with Refrigerant 407C and oil.

Each refrigerant circuit shall have a high and low-pressure cutout switch and a coil frost protection thermostat. The high pressure cutout shall be a manual reset control. Each low pressure control (loss of charge) and frost protection thermostat shall require a manual reset if the alarm condition occurs three times within any 24 hour period.

## Refrigeration Capacity Control

Refrigeration capacity control shall be accomplished by staging of the unit's multiple compressors. To maintain desired temperature control, the unit shall have a minimum of [two] [three] [four] steps of capacity control.

All compressor capacity control staging shall be controlled by the factory installed main unit control system.

## Electrical

Unit wiring shall comply with NEC requirements and with all applicable UL standards. All electrical components shall be UL recognized, where applicable. To provide for easy identification, all wiring and electrical components shall be numbered, color-coded and labeled according to the electrical diagrams provided with each unit. The main unit control panel shall be completely factory wired and contained in an accessible enclosure. The main control panel shall be provided with dead front covers over all line voltage components. A terminal board shall be provided for low voltage control wiring. Branch circuit fusing, 115V control circuit transformer with fuse, system switches and high temperature sensor shall also be provided.

Pilot knockouts shall be provided at the main control panel for field wiring entrance. The unit shall have a [single] [dual] [terminal block] [non-fused disconnect] for main unit power connection.

Each compressor shall be controlled by its own dedicated contactor, shall be individually fused and shall have thermal overload protection. The supply fan motor circuit shall include a dedicated contactor, external line break overload protection and dedicated fuse protection. Group fusing of components in lieu of individual fuse protection for each component is not acceptable.

The unit control system shall permit starting and stopping of the unit locally or remotely. The keypad/display and monitoring panel shall include a three position "on", "off", "auto" switch, an Alarm indication light and a Power indication light. The Alarm light shall provide a visual indication whenever a malfunction occurs and it shall remain until the malfunction is corrected. The control system shall be capable of providing a remote alarm indication. The unit control system shall provide for pump start, outside air damper actuation, smoke shutdown, emergency shutdown, remote heat enable/disable, remote cool enable/disable, heat indication, cool indication, fan interlock and fan operation.

## Non-fused Disconnect Switch

[A single non-fused disconnect switch shall be provided for disconnecting electrical power at the unit. The switch handle shall be visible, located at the front of the unit, and shall be accessible without unit entrance.]

[Dual non-fused disconnect switches shall be provided for disconnecting electrical power at the unit. One switch will service the supply fan plus the unit control system. The second switch will service the condensing unit section. Disconnect switch handles shall be visible, located at the front of the unit, and shall be accessible without unit entrance.]

## Phase Failure/Under Voltage Protection

A phase failure/under voltage protection device shall be provided to protect three-phase motors from damage due to single phasing, phase reversal and low voltage conditions.

## Water Flow Switch

A water flow switch shall be provided, factory installed, to verify water flow status at the unit. Compressor operation shall be disabled and an alarm signal provided if condenser water flow is lost. Unit operation will be restored when water flow has again been sensed. Water flow status shall be displayed at the unit's main controller.

## Freezestat

### (Units with Waterside Economizer)

A non-averaging type freezestat shall be factory installed on the entering face of the economizer coil. Upon sensing a freeze condition, the unit supply air fan will be shut down, the [economizer] [heating] [economizer and heating] valve will be driven to the full open position and an alarm signal will be provided. Unit operation will be restored following the manual reset of the freezestat.

## Freezestat

### (Units without Waterside Economizer)

A non-averaging type freezestat shall be factory installed on the leaving face of the hot water heating coil. Upon sensing a freeze condition, the unit supply air fan will be shut down, the heating valve will be driven to the full open position and an alarm signal will be provided. Unit operation will be restored following the manual reset of the freezestat.

## Battery Pack

The unit shall be provided with a factory mounted and wired rechargeable battery pack. The battery pack shall be available to provide control power to unit actuators in the event of a power failure.

## UV Lights

Unit to have factory-mounted UV lights located on the leaving air side of the cooling coil. Unit to have view port to allow for visual indication of operation through UV resistant glass. Unit to have door interlocks on each removable panel accessing UV light. Interlock to kill power to UV light when panel is removed.

Lamp and fixture to consist of a housing, power source, lamp sockets, and lamp. All components are to be constructed to withstand typical HVAC environments and are UL/C-UL listed. Housings are to be constructed of type 304 stainless steel and are to be equipped with both male and female power plugs with one type at each end to facilitate simple fixture-to-fixture plug-in for AC power.

Power source shall be an electric, rapid-type with overload protections and is to be designed to maximize radiance and reliability at UL/C-UL listed temperatures of 55°F–135°F. Power source will include RF and EMI suppression.

Sockets shall be medium bi-pin, single click safety, twist lock type and are to be constructed of a UVC-resistant polycarbonate.

Lamp shall be a high output, hot cathode, T8 diameter, medium bi-pin that produces UVGI of 254 nm. Each tube produces the specified output at 500 fpm and air temperatures of 55°F–135°F.

## MicroTech III Unit Controller

Each unit shall be equipped with a complete MicroTech III microprocessor based control system. The unit control system shall include all required temperature and pressure sensors, compressor control boards, heating control board, main microprocessor control board and operator interface. The unit control system shall perform all unit control functions including scheduling, [constant air volume, zone temperature control (SCC)] [constant air volume, discharge temperature control (DAC)] [variable air volume, cooling only discharge temperature control [with single-stage morning warm-up heat] (DAC)] [variable air volume, cooling/modulating heating discharge temperature control (DAC)] [duct static pressure control], [building static pressure control], unit diagnostics and safe-ties. All boards shall be individually replaceable for ease of service. All microprocessors, boards, and sensors shall be factory mounted, wired and tested.

The microprocessor shall be a stand-alone DDC controller not dependent on communications with any on-site or remote PC or master control panel. The microprocessor shall maintain existing set points and operate stand alone if the unit loses either direct connect or network communications. The micro-processor memory shall be protected from voltage fluctuations as well as any extended power failures. All factory and user set schedules and control points shall be maintained in nonvolatile memory. No settings shall be lost, even during extended power shutdowns.

The main microprocessor shall support an RS-232 direct connection to a product service tool or a modem. A [BACnet<sup>®</sup>/IP] [BACnet<sup>®</sup> MS/TP] [LonTalk<sup>®</sup>] communications port shall be provided for direct connection into the BAS network.

All digital inputs and outputs shall be protected against damage from transients or wrong voltages. Each digital input and digital output on the main microprocessor shall be equipped with an LED for ease of service. An alarm LED on the user interface shall provide quick visual identification that an alarm condition exists. All field wiring shall be terminated at a separate, clearly marked terminal strip.

The microprocessor shall have a built-in time schedule. The schedule shall be programmable from the unit keypad interface. The schedule shall be maintained in nonvolatile memory to insure that it is not lost during a power failure. There shall be one start/stop per day and a separate holiday schedule. The controller shall accept up to sixteen holidays each with up to a 5-day duration. Each unit shall also have the ability to accept a time schedule via BAS network communications.

If the unit is to be programmed with a night setback or setup function, an optional space sensor shall be provided. Space sensors shall be available to support field selectable features. Sensor options shall include:

1. Zone sensor with tenant override switch.

2. #1 plus a heating and cooling set point adjustment. (CAV-ZTC only)

The unit keypad/display character format shall be 20 characters x 4 lines. The character font shall be 5 x 8 dot matrix. The display shall be a supertwist nematic (STN) LCD display with black characters on yellow background for high visibility. For ease of service, the display format shall be English language readout. Coded formats with look-up tables shall not be acceptable.

The keypad interface shall be equipped with eight individual touch-sensitive membrane key switches that allow convenient navigation and access to all control functions. All control settings shall be password protected against unauthorized changes.

The user interaction with the display shall provide the following information:

1. Return air temperature
2. Supply air temperature
3. Outdoor air temperature (opt.)
4. Space air temperature (opt.)
5. Discharge air temperature
6. Entering condenser water temperature
7. Leaving condenser water temperature
8. Mixed air temperature
9. Outdoor enthalpy high/low (opt.)
10. Dirty filter indication
11. Airflow verification
12. Supply fan status
13. Supply vane position/VFD speed indication
14. Outside air damper position(opt.)
15. Duct static pressure
16. Duct static pressure #2 (opt.)
17. Building static pressure (opt.)
18. Cooling status
19. Cooling control method
  - a. Nearest
  - b. Average
20. Heating status
21. Dehumidification status
22. Control Temperature (changeover)
23. External exhaust fan status (opt.)
24. VAV output status
25. Fan operation status
26. Unit status
27. Time schedules
28. Up to four active alarms with time and date
29. Previous 8 alarms with time and date
30. Optimal start
31. Purge cycle
32. System operating hours
  - a. Fan
  - b. Cooling
  - c. Individual compressor
  - d. Heating
  - e. Economizer
  - f. Tenant override
  - g. Dehumidification

The user interaction with the keypad shall provide the following set points as a minimum:

1. Control modes
  - a. Off manual
  - b. Auto
  - c. Heat/cool
  - d. Cool only
  - e. Heat only
  - f. Fan only
2. Occupancy mode
  - a. Auto
  - b. Occupied
  - c. Unoccupied
  - d. Tenant override
3. Control temperature (changeover)
  - a. Return air temperature
  - b. Space temperature
  - c. Network signal
  - d. Outdoor air temp. (VAV w/ mod. heat)
4. Cooling with deadband
5. Heating with deadband
6. Cooling and heating supply
7. Cooling & heating supply reset options
  - a. Return air temperature
  - b. Outdoor air temperature
  - c. Space temperature
  - d. Airflow (VAV)
  - e. No reset
  - f. Network signal
  - g. External (1-5 VDC)
8. Temperature alarm limits
  - a. High supply air temperature
  - b. Low supply air temperature
  - c. High return air temperature
9. Lockout control
  - a. Compressor lockout
  - b. Heat lockout
10. Lead-lag on compressors
  - a. Auto
  - b. Disabled
11. Compressor Inter-stage timers
12. Night setback and setup space temp.
13. Duct static pressure reset options
  - a. No reset
  - b. Network
14. Building static pressure (opt.)
15. Minimum outdoor airflow reset
  - a. Percent of CFM capacity
  - b. External reset (1-5 VDC)
  - c. Fixed outdoor damper position
16. Economizer changeover
  - a. Enthalpy
  - b. Dry bulb
17. Current time and date
18. Tenant override time
19. Occupied/unoccupied time schedules
20. One event schedule

21. Holiday dates and duration

22. Service mode

- a. Timers normal (all time delays normal)
- b. Timers fast (all time delays 20 sec.)
- c. Mode normal (unit on)

## Open Communications Protocol

The unit control system shall have the ability to communicate to an independent Building Automation System (BAS) through a direct [BACnet<sup>®</sup>/IP] [BACnet<sup>®</sup> MS/TP] [LonTalk<sup>®</sup>] communications connection.

[BACnet<sup>®</sup> Communications shall conform to the BACnet<sup>®</sup> protocol (ANSI/ASHRAE135-2001). A protocol implementation conformance statement (PICS) shall be provided. Multiple units may be connected in a common communications network.]

[Communications shall conform to LonMark<sup>®</sup> Interoperability Guidelines and shall be certified. Controls shall conform to the [Discharge Air Controller (DAC)] [Space Comfort Controller (SCC)] profile.]

Through communications, the BAS System Integration (SI) contractor shall be capable of interacting with the individual self-contained unit controllers in the following ways:

1. Access to [quantity and description from specification] “read only” variables and [quantity and description from specification] “read & write” variables.
2. Set the unit's operating mode.
3. Monitor controller inputs, outputs, setpoints, parameters and alarms.
4. Change controller setpoints and configuration parameters.
5. Clear alarms.
6. Reset the cooling discharge air temperature setpoint (DAC units).
7. Reset the heating discharge air temperature setpoint (DAC units with modulating heat).
8. Reset the duct static pressure setpoint (DAC units).
9. Set the heat/cool changeover temperature (DAC units).
10. Set the representative zone temperature (DAC units).

It will be the responsibility of the SI Contractor to integrate the self-contained unit data into the BAS to affect the integrated building control logic and centralized system workstation interface.



### ***McQuay Training and Development***

Now that you have made an investment in modern, efficient McQuay equipment, its care should be a high priority. For training information on all McQuay HVAC products, please visit us at [www.mcquay.com](http://www.mcquay.com) and click on training, or call 540-248-9646 and ask for the Training Department.

### ***Warranty***

All McQuay equipment is sold pursuant to its standard terms and conditions of sale, including Limited Product Warranty. Consult your local McQuay Representative for warranty details. Refer to Form 933-430285Y. To find your local McQuay Representative, go to [www.mcquay.com](http://www.mcquay.com).

### ***Aftermarket Services***

To find your local parts office, visit [www.mcquay.com](http://www.mcquay.com) or call 800-37PARTS (800-377-2787). To find your local service office, visit [www.mcquay.com](http://www.mcquay.com) or call 800-432-1342.

This document contains the most current product information as of this printing. For the most up-to-date product information, please go to [www.mcquay.com](http://www.mcquay.com).

Products manufactured in an ISO certified facility.

