



**Catalog 770-14**

# HiLine™ Vertical Stacking Fan-coil Units

Type HSS & KZZ



ARI 440



CUL Listed

# Contents

Application flexibility .....	2
McQuay HiLine™ fan-coil units.....	2
Installing The HSS (Basic) Unit:.....	9
Installing the KZZ (Knock-down) Unit:.....	9
HiLine™ selection data .....	13
Model KZZ (Knock-down Unit) Unit Sizes S03 Thru S08 (300 thru 800 cfm) .....	17
Model HSS (Basic Unit) Unit Sizes S03 Thru S08 (300 thru 800 cfm).....	18
Riser Location — HSS and KZZ Unit Sizes S03 Thru S08 (300 thru 800 cfm).....	19
Model HSS (Basic Unit) Unit Sizes S10 Thru S12 (1000 thru 1200 cfm).....	20
Riser Location — HSS Unit Sizes S10 and S12 (1000 thru 1200 cfm).....	21
Engineering guide specifications.....	25

## ARI certification, U.L. and CUL listing

McQuay HiLine fan-coil units are tested and rated in accordance with Air Conditioning and Refrigeration Institute (ARI) Standard 440 and certified in accordance with the ARI certification program. ARI certification assures you full rated performance and offers confidence in unit selection.

HiLine fan-coil units are listed by Underwriters Laboratories as complying with nationally recognized safety standards for fan-coil air conditioning units.



"HI-F" and "HiLine" are registered trademarks of McQuay International.  
 "McQuay" is a registered trademark of McQuay International.

©2011 McQuay International. All rights reserved throughout the world.

"Bulletin illustrations cover the appearance of McQuay International products at the time of publication and we reserve the right to make changes in design and construction at anytime without notice."

# McQuay HiLine™ fan-coil units

The McQuay HiLine fan-coil air conditioning units are designed for use in multiple floor apartments, office buildings, hotels and other similar applications and require a minimum amount of floor space. Just one HiLine unit may do the job that formerly required more than one conventional unit.

The results of many years of experience in the development, design and manufacture of fan-coil air conditioners have been incorporated in the McQuay HiLine units to provide highly efficient, quiet performance; individual thermostatic control; simple, low cost installation; application flexibility; and low maintenance and operating costs with no sacrifice in room comfort, design, or appearance.

For the ultimate in design, performance, efficiency, flexibility of application, and ease of installation and maintenance, look to McQuay HiLine fan-coils.

## Application flexibility

Two distinct designs are available with the complete flexibility necessary for any application requirement.

- **Low cfm design** - The 300 through 800 cfm blow-through configuration units are designed to meet individual room control requirements.
- **High cfm design** - The 1000 and 1200 cfm draw-through configuration units are designed for multiple discharge arrangements so that one unit can serve more than one room.

Both designs are available for two-pipe and four-pipe systems with single, double, triple and top discharge arrangements. Optional equipment is available to provide complete application flexibility.

Contact your McQuay representative for a copy of the McQuayTools™ selection program to choose a unit meeting your needs.



## Nomenclature

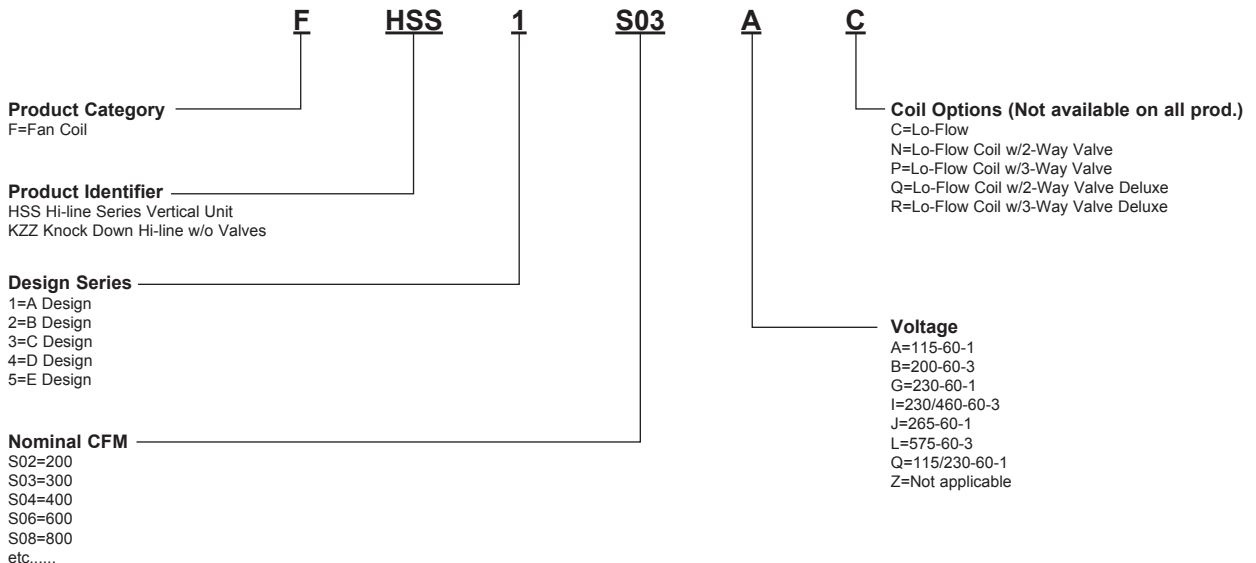

# Low cfm design (300 thru 800 cfm)

## Blow-Through Units to Meet Individual Room Requirements

**NEUTRAL UNIT SHOWN**  
(Risers in back)

**LOW SOUND LEVEL OPERATION** - The low cfm design features a quiet, energy efficient motor and fan assembly, carefully located within a fully insulated cabinet to provide low sound level operation.

**RISERS** - Factory cut 104" long. No on-the-job cutting required. Supply and return risers have factory installed sweat ball valves and are factory insulated

**FAST, SIMPLE INSTALLATION** - Simply stack one unit above the other, sweat the couplings to the risers and connect the power. The unique non-stop slip couplings require only one person for setting and connecting.

**DISCHARGE ARRANGEMENTS**  
- Single, double, triple and top discharge arrangements are available.

**CONTROLS** - Face mounted, plug-in type, combination 3-speed switch and thermostat. Thermostat electrical box is adjustable for wall thickness. No wiring required.

**CABINET** - Heavy gauge galvanized steel. Fully insulated for quiet operation.

**ACCESS & SOUND BAFLE PANEL** - Insulated galvanized steel. Easily removed for complete access for service.

Optional valve packages can be provided for 24V, 115V, and 277V.

**COILS** - High efficiency type for full rated capacity. AHRI certified.

**REMOVABLE CHASSIS**  
- All components are mounted on a single removable chassis so that a different capacity chassis can be installed in the same cabinet should future needs require it.

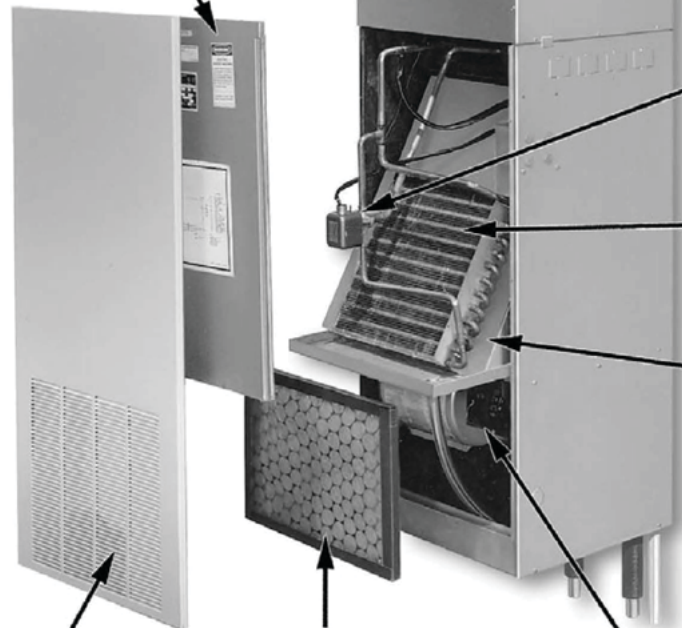

**RETURN AIR GRILLE PANEL** - Heavygauge steel with stamped grille and attractive Antique Ivory finish. Available as an accessory.

**FILTER** - Easily accessible by simple removal of return air grille panel.

**MOTOR & FAN ASSEMBLY** - Quiet, energy efficient, permanent split capacitor motors and centrifugal fans for low sound level. Fan housings are of a split type design or have separate inlet rings to allow easy removal of the fan motor.

**OPPOSITE HAND UNITS** - Two adjacent room units can be connected to a single set of risers and still retain individual room temperature control. Twin units must be joined in the field. Reverse piping for same hand units not available.

# High cfm design (1000 thru 1200 cfm)

## For Multiple Discharge Arrangements

**SPECIALLY DESIGNED FOR HIGH CFM PERFORMANCE** - These draw-through type units are ideal for luxury hotel and condominium type buildings where multiple discharge arrangements with a common return air location, high cfm performance and quiet operation are required.

### NEUTRAL UNIT SHOWN (Risers in back)

**FAST, SIMPLE INSTALLATION** - Simply stack one unit above the other, sweat the couplings to the risers and connect the power. The unique non-stop slip couplings require only one person for setting and connecting.

**RISERS (Not shown)** - Factory cut 104" long. Supply and return risers are factory insulated. The unique non-stop slip couplings require only one person for unit setting and connecting.

**DISCHARGE ARRANGEMENTS** - Single, double, triple and top discharge arrangements are available.

**CABINET** - Heavy gauge galvanized steel. Fully insulated for quiet operation.

**CONTROLS** - Unit-mounted combination 3-speed switch and thermostat. Thermostat electrical box is adjustable for wall thickness. Thermostat wiring required in the field (optional mox connections can be provided).

**OPPOSITE HAND UNITS** - Two adjacent room units can be connected to a single set of risers and still retain individual control of each unit. Twin units must be joined in the field. Reverse hand piping for same hand units not available.

**MOTOR & FAN ASSEMBLY (Not shown)** - Quiet, energy efficient, permanent split capacitor motors and centrifugal fans, mounted in the draw-through position with a common return air location, provide high cfm performance with low sound level.

**SWEAT BALL VALVES** - are factory mounted on coil.

Optional valve packages can be provided for 24V, 115V, and 277V.

**COILS** - High efficiency type for full rated capacity. ARI certified.

**RETURN AIR GRILLE PANEL** - Heavy gauge steel with stamped grille and attractive Antique Ivory finish.

**ACCESS & SOUND Baffle PANEL** - Easily removed for complete access to internal controls, motor and fan assembly for service.

**FILTER** - Easily accessible by simple removal of return air grille panel.

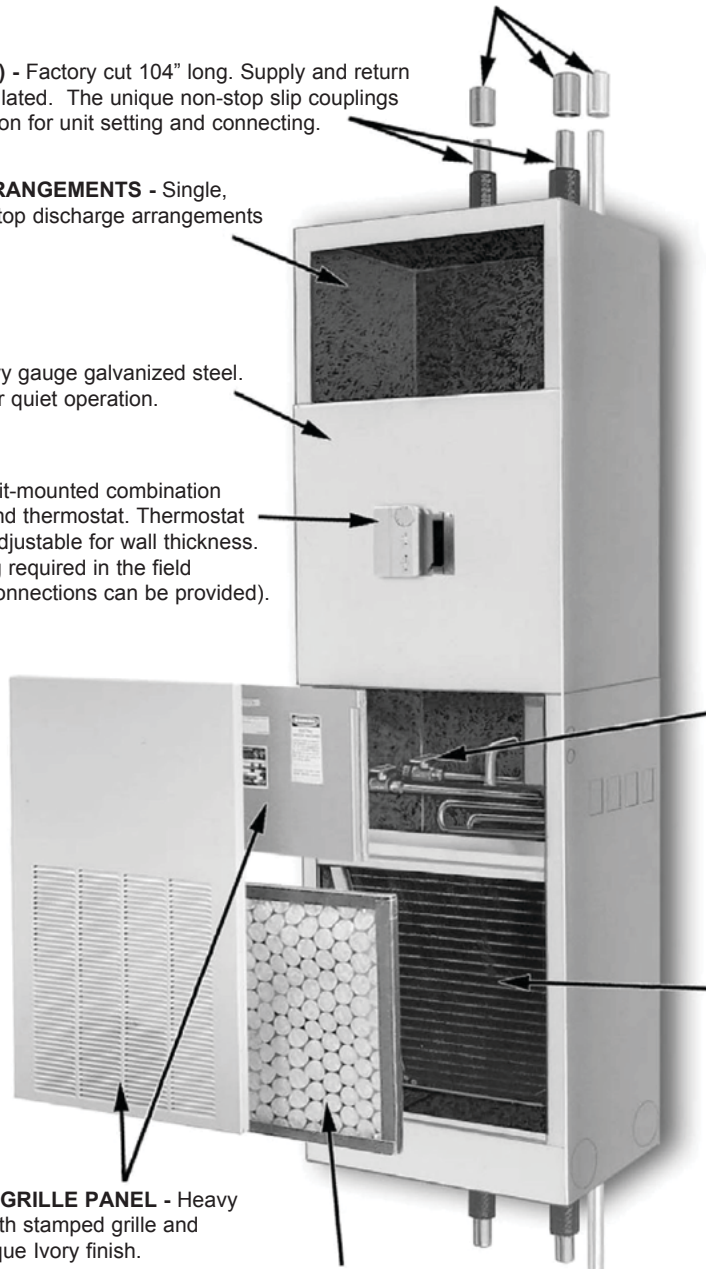

# Design features for high performance and low operating cost



**Telescoping  
Thermostat Box**



**Plug-in Field Mounted Thermostat**



**Fan and Motor Assembly**



**Sizes  
S03 & S04**

**Sizes  
S06 -S12**



## Unit configuration

Unit sizes S03 through S08 feature a blow-through design with completely removable chassis. The motor, fan assembly, coil(s), drain pan and valve packages are mounted on a compact chassis which slides through the return air grille and access panel.

Unit sizes S10 and S12 feature a draw-through design. Filter, drain pan and drain line are accessible by removing the return air grille. Controls, valves, motor and fan assembly are accessible by removing the access panel.

## Knock-down unit

The KZZ knock-down unit configuration, available for unit sizes S03 through S08, allows installation, leak testing and insulation of the risers and stub-outs prior to the unit placement. Risers can be field provided or factory supplied and shipped to the jobsite before the units. After riser installation, the bottom half of the unit is set in place. Connections are then made to the supply, return and drain risers as well as the power supply. Then the top half of the unit is installed.

## Control systems

A variety of thermostats, unit or wall mounted, are offered to control all different options for fan and valve cycling. For unit mounted thermostats all wiring is provided to the control box for easy field installation (optional Molex connections are available upon request). A 10K thermistor is mounted in all units. It can be used for factory provided thermostats or for field provided controls. The thermostat electrical box is adjustable for any wall thickness up to 3-7/8" and is provided with a 1/2" mud ring (an optional 5/8" mud ring can be provided upon request).

## Thermostats

- Unit mounted 2 or 4-pipe systems (24v-277v)
- Wall mounted 2 or 4-pipe systems (24v-277v)
- Automatic or manual changeover
- Digital display
- Optional quick connect for unit mounted thermostats

(Please reference ED 18513 for thermostat availability and options)

## Efficient, quiet fans and motors

Three-speed, permanent split capacitor motors coupled with DWDI forward curved direct drive fans provide efficient operation. Motors have sleeve bearings, oilers and inherent automatic reset thermal overload protection. Unit sizes S03 through S04 have a two-piece fan housing with integral scroll and inlet. Unit sizes S06 through S12 have a heavy-gauge steel fan housing with integral scroll and separate inlets. All fan wheels are statically and dynamically balanced. Efficient fans, PSC motors, resilient motor mounts and a fully insulated cabinet provide quiet operation.

## Factory- and field-installed risers

Insulated risers are available factory-installed or can be shipped with or prior to the units for field installation (factory-installed risers are not available for KZZ knock-down units). See details below. On S03 through S08 units, sweat ball valves are included with factory risers.

All copper risers are factory cut to 104" in length. Non-stop slip couplings for supply and return risers and stop type couplings for drain risers may be ordered separately. Insulation meets or exceeds current flammability classification UL94. Insulation to cover slip couplings must be field provided.

- Supply and return risers are of type "L" copper in nominal 3/4", 1", 1-1/4", 1-1/2", 2", 2-1/2" diameters with 3/4" factory installed, closed cell flexible foam insulation.
- Drain risers are available in PVC or type "L" copper (insulation included), in nominal 3/4" or 1-1/4" diameter.
- Optional 1/2" closed cell insulation is available for supply, return, and drain risers.
- Optional M or K type copper is available with closed cell insulation.

### Note:

When risers are factory-mounted on master-slave units, the master unit is shipped with the riser attached. This riser will have 3" stubs that match up to the slave unit. The slave unit will not have ball valves attached to the valve package. See Page 22 for master-slave riser locations. Ball valves, if required, must be purchased separately and will ship loose for field mounting. See IM 283 for additional information.

## High performance coils

Two-pipe system units have a standard low-flow, high capacity cooling/heating coil. Four-pipe system units have a standard low-flow, high capacity cooling coil and a one-row heating coil. All coils are seamless copper tubes in a staggered pattern and feature the patented HI-F rippled and corrugated aluminum fins for high heat transfer efficiency. Full depth collars are drawn in the fin stock for accurate control of fin spacing and completely cover the copper tubes to lengthen coil life. Copper tubes are mechanically expanded into the fin collars to provide a positive primary to secondary surface bond. Manual air vents on coils are provided. Ball valves on supply and return lines are provided at the coil on S10 and S12 models. Coils are positioned for rapid condensate drainage, balanced airflow and full rated capacity. Unit capacities are ARI certified.

## Factory-installed valve packages and options

Multiple configurations of two- and three-way motorized valves are available as described below, without or without unions. Ball hand valves and flow metering devices are also available.

- Standard high voltage valve package 115–277v (includes 2 or 3-way motorized On/Off valve and shut-off valves for supply and return)
- Deluxe high voltage valve package 115–277v (includes 2 or 3-way motorized On/Off valve, strainer, circuit setter, P/T ports, and shut-off valves)
- Optional 24v On/Off or modulating valves
- Custom valve packages available
- Fixed flow control
- Optional stainless steel braided hoses

## Fast, low-cost installation

Installation time is minimized by the unit's design, riser slip couplings, and unit mounted controls. Units are completely factory assembled and wired and have individual thermostat controls. Riser are factory cut to 104" in length and insulated. Optional riser couplings are available. Installation is accomplished by simply stacking the units one above the other floor-by-floor, brazing the couplings and risers together, and connecting the power. Only one person is required for installation because the slip couplings eliminate the requirement for perfect unit alignment with the swedged riser joints of other manufacturers.

## Twin units

To reduce installed cost, two units of opposite hand on each floor can share a set of supply, return and drain risers. Individual thermostat control is retained by each unit. Units can be placed side-to-side, or side-to-back

## Coils

High-capacity, low-flow heating/cooling coils are standard. Separate row heating coils are available for 4-pipe systems. All coils are furnished with manual air vents..

### Riser, Slip Coupling and Insulation



### Optional Valve Package Components

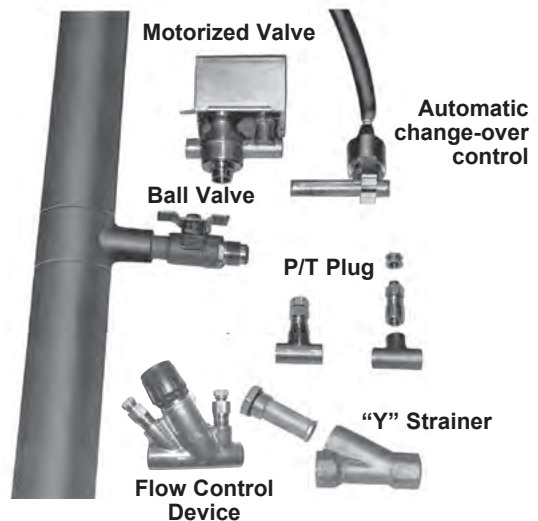

# Optional features and accessories

## Electric Heat



## Motors

115/60/1 and 277/60/1 motors are available. All motors are 3-speed permanent split capacitor type with sleeve bearings, oilers, resilient mounts and automatic reset internal overload protection.

## Electric heat

A specially designed, optional electric heat unit is available for supplementary heat between seasons or to provide full electric heating. All heaters are protected by automatic-reset, high-limit thermal cutouts. Service access to electric heaters is through the return air grille and access panel for unit sizes S03 through S08. It is through the discharge grille for unit sizes S10 and S12.

## Cabinet closed cell insulation

Cabinets can be supplied fully insulated with 1/2" closed cell insulation (1/2" multi-density glass fiber is standard).

## Fresh air dampers

A motorized, two-position fresh air damper kit is available for field mounting in one of three locations. A manual fresh air damper kit is also available. Outside fresh air must be tempered before entering the unit if freezing conditions are expected.

## Fresh Air Dampers



## Return air grilles

Return air grille options include the standard stamped return air grille or an optional bar type grille. Both grilles are manufactured of heavy-gauge steel and coated with an electrostatically applied baked-on Antique Ivory finish. A plaster frame is standard to provide easy access for filter replacement.



## Discharge Arrangements

## Discharge Grilles



## Single Deflection

## Double Deflection

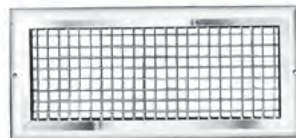

## Filters

One inch throwaway filters are standard.

## Discharge arrangements and grilles

Two sizes of aluminum single deflection or double deflection grilles are available. Grilles may be field mounted on the panel opposite the riser and on one or both panels adjacent to the risers. A top discharge opening is also available.

## Line-of-sight baffle

A line-of-sight baffle is available for applications involving two opposing discharge openings.



## Installing The HSS (Basic) Unit:

1. The McQuay HiLine basic unit is simply lifted into place directly above the unit on the floor below.
2. This unit has been set in place, ready to accept the unit above.
3. Next, using factory available slip couplings, connect the prefabricated supply, return and drain risers together, connect the power, and your basic installation is completed. Wall board can be applied directly to the unit.
4. After the unit has been "furred-in" and the room painted, it takes only a few minutes to attach the grilles and plug in the thermostat.
5. When the installation is completed, the unit blends in beautifully with the surrounding decor and takes up a minimum of floor space.



## Installing the KZZ\* (Knock-down) Unit:

1. Unlike the basic unit, the KZZ unit allows installation, leak testing and insulation of the risers and stubouts prior to unit placement.
2. The bottom half of the unit is set in place, and the supply, return and drain risers are connected to the unit along with the power supply.
3. The top half of the unit is then easily installed and the factory supplied thermostat harness is connected.
4. Finishing the installation is the same with either the standard HSS model or the knock-down KZZ model.
5. Both HiLine units can be located away from an outside wall to form a curtain cove, or built into a room divider. It's easy to conceal the units in a corner or build them into a wall to serve two or more rooms. And, of course, the creative architect will think of many more applications for this versatile unit.

\*The "KZZ sectioned cabinet for room air conditioning unit" is covered under U.S. Patent No. 4,426,120.

# Application considerations

## Piping systems

Reverse Return Piping Systems - If possible, the same size HiLine units should be installed one above the other all the way up each stack in the building. This way, each unit in the stack requires the same amount of water. No balancing is required, because the loop of water from each unit travels the same distance and has the same pressure drop.

Our experience indicates that the reverse return piping system, Figure 1, is the most popular one because the system tends to be self-balancing. Only one express riser is required to gather the return water, at the top or bottom of the building, and return it to the boiler or chiller.

**Direct Return Piping System** - In the direct return piping system, Figure 2, each unit must be individually balanced to obtain proper water flow through each unit.

## Expansion and contraction

Proper allowance must be made for pipe expansion. Provisions have been designed into the HiLine unit to allow for plus or minus 1" of riser movement. For riser systems where the movement exceeds  $\pm 1$ ", provisions must be provided in the riser system to restrict the movement. As a rule of thumb, 100 feet of copper pipe will expand 1" when exposed to a 100°F temperature difference. See Figure 4 for thermal expansion of copper risers. The temperature difference is the difference between the temperature at which the piping is installed and the water temperature during operation. On a two-pipe system, this temperature difference becomes even greater due to the change in water temperature from cooling to heating.

One method of limiting riser expansion is by anchoring the riser pipes at the center of the riser stack and allowing the pipes to expand away from the anchor point. Thus, a 200 ft. length would expand approximately 1" each way. Another method is anchoring the riser pipes at the end and absorbing the expansion with an expansion compensator. If an expansion compensator is used, the pipe should be guided. In some situations, a combination of both methods may be required. The risers must be secured at some point as the units have not been designed to support the riser weight.

## Number of floors per riser

The standard HiLine unit with service valves, expansion loops, etc., will operate at 250 PSI working pressure which is equivalent to a 35 to 40 story building.

## Selection of riser piping

Riser piping should be selected based on economic considerations. Detailed information may be found in the ASRHAЕ Handbook series. The guidelines offered in Figure 4 are based on water velocity only. A water velocity of 2 FPS is considered to be the minimum requirement for entraining and carrying air with water flow. Water velocities of over 8 FPS may cause undue erosion of water pipe. Risers may be sized on the highest water velocity that will not cause noise or erosion. We recommend that the water velocity in risers and units fall within the range of 4 FPS to 6 FPS. Since HiLine units have risers outside the unit cabinet and usually within a partition wall, noise should not be a problem. Riser sizes need not be changed at every floor to accommodate flow changes but may be carried at one size until water velocities fall outside the recommended ranges.

## Contractor piping responsibility

Factory available copper riser couplings are non-stop type for ease of installation. PVC couplings have stops. Field installation involves clamping the slip coupling in place and brazing or sweat soldering it to the risers above and below. PVC couplings are field cemented to the drain risers. Reducing couplings, anchors and expansion compensators, if required, must be provided by the contractor.

Insulation to cover slip couplings must be field provided. Providing a good cement bond at the joints between the field installed insulation and the factory installed riser insulation is the contractor's responsibility.

## Fire stop

For building code compliance, a fire stop must be provided by the contractor in the riser opening between floors and between twin units serving adjacent rooms.

Figure 1. Reverse Return Piping System

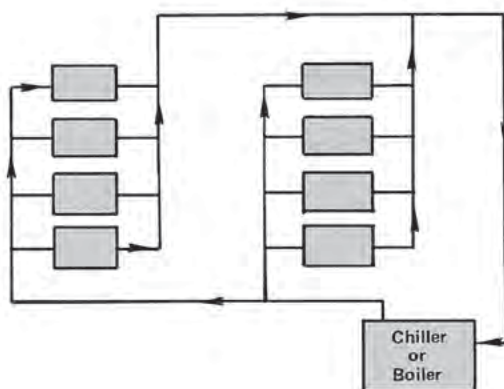
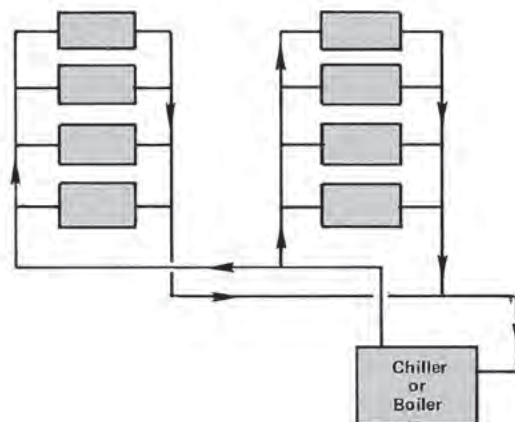

Figure 2. Direct Return Piping System



## **Insulation limitations**

Under high humidity start-up conditions, care should be taken by utilizing a gradual pull-down to minimize sweating of cabinet and/or risers.

## **Temperature control**

A wide variety of fan and valve cycle control systems are offered for McQuay HiLine units. Valve cycle control systems have a higher first cost but offer significantly lower operating costs than fan cycle systems. Valve cycle control systems provide superior temperature control resulting in improved occupant comfort.

Both unit mounted and remote wall mounted thermostats are available. The 10K thermistor is positioned in front of the filter and is provided with all units. The thermostat electrical box is field adjustable for any wall thickness up to 3-7/8". Direct sunlight falling on thermostats for either unit or remote mounted control applications should be avoided.

## **Twin units**

Equipment and installation costs can be significantly reduced by designing a floor layout involving twin units. Twin units, of opposite hand, are placed side-to-side, or side-to-back and share a common set of risers. Individual thermostat control is retained by each unit. Twin unit risers have two sets of stubouts to accept piping from both units. A short link of field supplied copper tubing may be required depending upon wall thickness between units.

Figure 4. Type "L" Copper Riser Pressure Drop

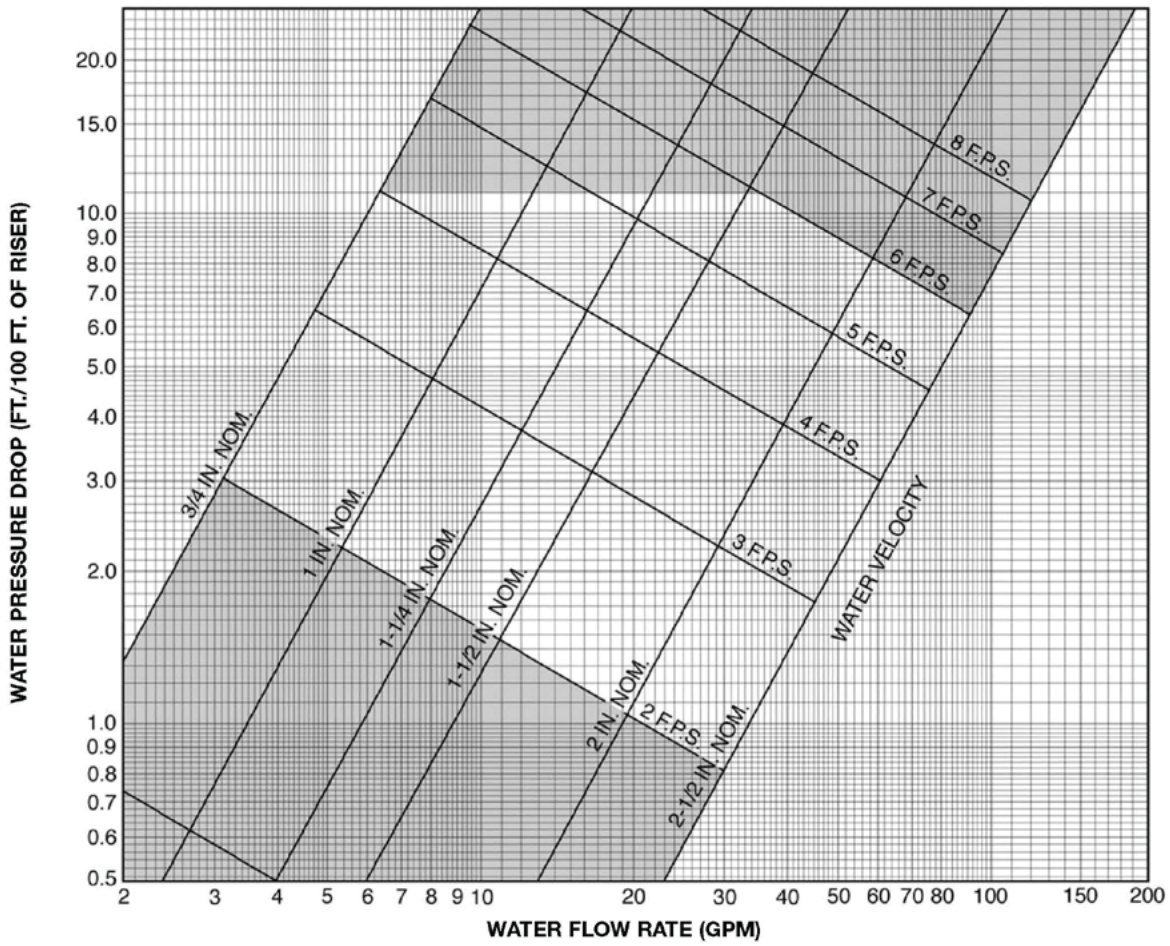

AREA OUTSIDE OF RECOMMENDED DESIGN RANGE.

Figure 5. Thermal Expansion of Copper Risers

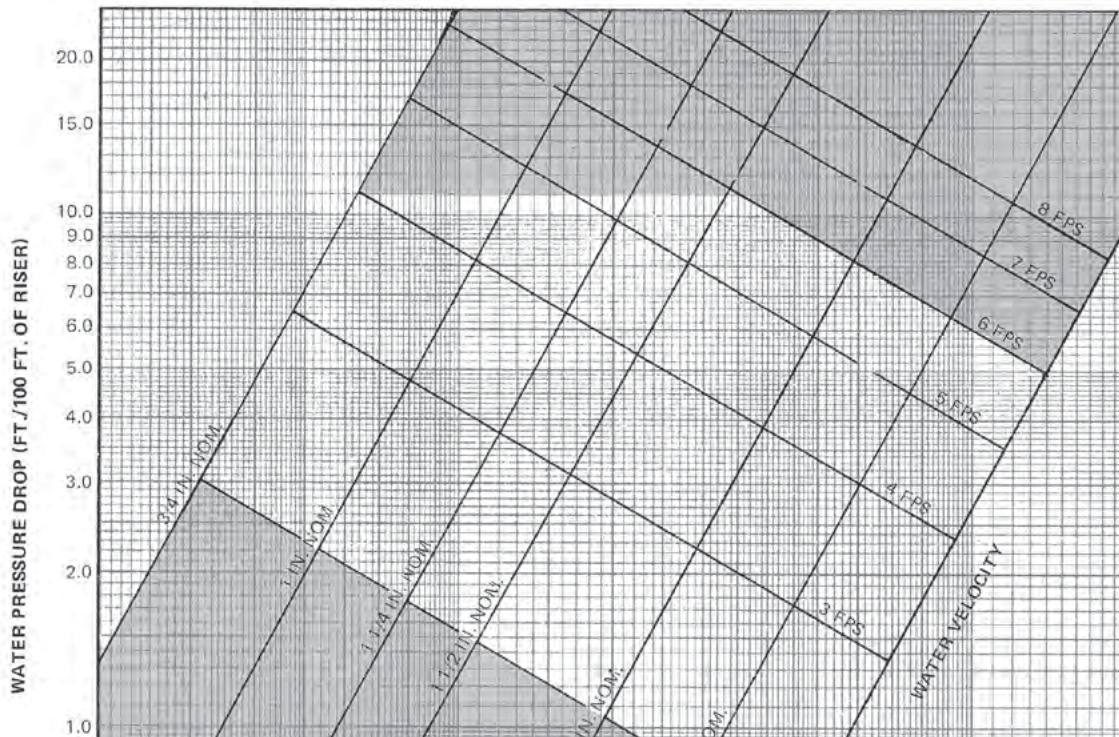

# HiLine™ selection data

## System design

The achievement of an efficient fan coil system is dependent upon accurate system design and proper equipment selection. Variations, limitations and control of fan coil systems, design conditions and design load calculations are not described in detail in this catalog. More detailed information may be found in the ASHRAE Handbook series.

Prior to selecting the individual unit sizes, the design engineer must fix or determine the following factors:

1. Inside and outside wet and dry bulb temperatures.
2. Method of introducing the ventilation.
3. Wet and dry bulb temperatures of the air mixture entering the unit coil.
4. Total and sensible heat gains and losses of the area to be served.
5. Properties of the heating and cooling mediums.
6. Available electric power service.
7. Any special design requirements of the building or system.

## Computer fan coil selection

The capacity ratings presented in this catalog are provided for initial unit selection only. Unit size selection should be determined by using the SelectTools™ fan coil selection computer program. Water cooling and heating capacities, unit airflow, static pressure, electric heat, glycol solutions and jobsite elevation are all incorporated into the program to provide the best possible selection. Consult your representative for a selection tailored to your application.

Unit sizes for the ideal system should be selected by calculating the peak load requirements due to unusually high occupancy or severe climatic conditions and with fan operating at high speed. Ordinary day to day cooling and heating requirements are then achieved at low and medium speeds. Ventilation requirements should be considered along with the following to determine the proper unit size.

**Cooling Coil Requirements** - Having checked the minimum unit size to meet the ventilation requirement, the unit size is generally selected on the basis of matching the sensible cooling capacity of the unit with the calculated requirements when operating at high speed.

The initial unit selection should be checked for air volume in the design system and the cooling capacities checked at the actual operating conditions. While units selected on the basis of sensible load will generally meet the total cooling load, total load should be checked in all cases.

**Coil Type** - Standard low flow coils are available for all units sizes to permit unit selections for optimum performance.

Low flow coils are designed to meet both the normal cooling and heating requirements while operating with reduced GPM and correspondingly higher water temperature rises. Their use is enhanced by the lower first cost of both riser piping and pump plus lower overall fan coil unit and water pump operating cost.

**Heating Requirements** - Heating requirements for two-pipe systems are generally met by employing the same water flow rate as cooling and adjusting the entering hot water temperature to obtain a matching unit heat output at low fan speed. Four-pipe systems are generally designed by specifying a design hot water temperature and adjusting the flow rate through the separate heating coil to meet the required heat load with the fan operating at low speed.

Maximum water temperature in coils should be limited to 200°F (160°F for HSS sizes S10 and S12), and should be adjusted to reflect outside temperatures.

Electric heaters are available for primary year-round heating or intermediate between-seasons heat loads for twopipe systems when chilled water is in the system. **Units having top duct discharge and electric heat must have a discharge duct face area equal to or greater than the top duct opening.**

# ARI approved standard ratings

**Table 2. Low Flow Coil Water Cooling Capacity Ratings<sup>1</sup>**

UNIT SIZE	COOLING CAPACITY <sup>2</sup>		WATER FLOW (GPM)	WATER FLOW P.D. (FT-WC)
	(TOTAL BTUH)	(SENSIBLE BTUH)		
S03	10500	7200	2.0	14.6
S04	17000	11400	3.5	44.7
S06	22200	14200	4.6	28.8
S08	28800	20100	5.7	44.1
S10	39600	26600	7.9	29.7
S12	44900	30400	8.9	39.6

**NOTES:**

- 1 Rated in accordance with AHRI Standard 440. Cooling capacities based on 80°F DB/67°F WB entering air, 45°F entering water, 10°F water temperature rise and high fan speed. See Table 7 for air volume capacities.
- 2 For cooling coil capacity ratings at conditions other than that listed, refer to the McQuayTools™ computer selection program or consult your McQuay representative.

**Table 3. Low Flow Coil Water Heating Capacity Ratings<sup>1</sup>**

UNIT SIZE	HEATING CAPACITY <sup>2</sup>	WATER FLOW (GPM)	WATER FLOW P.D. (FT-WC)
	(SENSIBLE BTUH)		
S03	20940	2.2	9.8
S04	25970	2.8	22.1
S06	38320	3.9	15.5
S08	48560	4.9	22.6
S10	64720	6.6	14.5
S12	77600	7.9	20.8

**NOTES:**

- 1 Water heating coils rated at 70°F DB entering air, 140°F entering water, 20°F water temperature drop and high fan speed.
- 2 For heating coil capacity ratings at conditions other than that listed refer to the McQuayTools™ computer selection program or consult your McQuay representative.

**Table 4. Separate Hot Water Coil Water Heating Capacity Ratings<sup>1</sup>**

UNIT SIZE	HEATING CAPACITY <sup>2</sup>	WATER FLOW (GPM)	WATER FLOW P.D. (FT-WC)
	(SENSIBLE BTUH)		
S03	12240	1.2	1.6
S04	16380	1.7	3.5
S06	22200	2.2	7.2
S08	25600	2.6	9.4
S10	40200	4.1	27.5
S12	46530	4.7	39.0

**NOTES:**

- 1 Water heating coils rated at 70° F DB entering air, 140°F entering water, 20°F water temperature drop and high fan speed.
- 2 For heating coil capacity ratings at conditions other than that listed refer to the McQuayTools™ computer selection program or consult your McQuay representative.

# Technical data

**Table 5. Air Volume versus External Static Pressure.**

UNIT SIZE	EXTERNAL STATIC PRESSURE (INCHES H2O)																				
	0.00			0.05			0.10			0.15			0.20			0.25			0.30		
	HI	MED	LO	HI	MED	LO	HI	MED	LO	HI	MED	LO	HI	MED	LO	HI	MED	LO	HI	MED	LO
S03	339	258	183	311	243	173	281	222	159	249	197	140	—	—	—	—	—	—	—	—	—
S04	408	310	221	397	298	207	384	284	193	368	268	178	350	252	160	—	—	—	—	—	—
S06	609	519	422	588	499	404	565	479	383	539	456	360	512	429	315	—	—	—	—	—	—
S08	798	621	452	781	606	440	759	590	428	736	574	416	712	556	402	686	535	386	—	—	—
S10	1020	800	646	1000	780	630	976	761	614	950	741	598	923	720	581	895	698	564	868	677	547
S12	1220	972	778	1192	954	765	1164	932	755	1137	910	748	1109	887	745	1080	865	747	1050	840	753

**NOTES:**

Air volumes based on 115/60/1 electrical services, normal unit features and dry coils.

Medium and low speed air volume based on unit performance in a system with tabulated external static pressure produced at high speed.

**Table 6. Motor and Physical Data.**

MODEL NUMBER	NOMINAL MOTOR DATA AT HIGH SPEED				RETURN AIR FILTER SIZE	MAXIMUM DISCHARGE GRILLE SIZE
	115/60/1		265/60/1			
	AMPS	WATTS	AMPS	WATTS		
S03	0.65	70	0.40	70	13-3/4" x 18-7/8" x 1"	16" x 12"
S04	1.30	146	0.45	120	13-3/4" x 18-7/8" x 1"	16" x 12"
S06	1.60	218	0.70	200	13-3/4" x 18-7/8" x 1"	16" x 12"
S08	2.40	314	1.10	290	13-3/4" x 18-7/8" x 1"	16" x 12"
S10	3.60	350	1.30	350	(1) 24" x 24" x 1"	24" x 14"
S12	4.80	498	2.10	500	(1) 24" x 24" x 1"	24" x 14"

**Table 7. Approximate HSS Shipping Weights (Lbs.)**

HKD UNIT SIZE	SINGLE UNIT, NO PALLET	SINGLE UNIT with PALLET	TWO UNITS with PALLET	FOUR UNITS with PALLET1
S03	155	205	380	720
S04	160	210	390	740
S06	175	225	420	800
S08	180	230	430	820
S10	256	306	585	1130
S12	267	317	605	1180

**NOTES:**

1 Standard shipping arrangement.

**Table 8. Approximate KZZ (Knock-down Unit) Shipping Weights (Lbs.)**

HKD UNIT SIZE	SINGLE UNIT, NO PALLET	TWO UNITS, with PALLET	OUR UNITS, WITH PALLET1
S03	155	380	720
S04	160	390	740
S06	175	420	800
S08	180	430	820

**NOTES:**

1 Standard shipping arrangement.

**Table 7. Electric Heat Data.**

UNIT SIZE	120V/60/1			265/60/1		
	WATTS	BTUH	AMPS	WATTS	BTUH	AMPS
S03	1000	3413	8.3	—	—	—
	—	—	—	—	—	—
	2000	6826	16.7	2000	6826	7.2
	—	—	—	—	—	—
	—	—	—	3000	10239	10.8
S04	1000	3413	8.3	—	—	—
	—	—	—	—	—	—
	2000	6826	16.7	2000	6826	7.2
	—	—	—	—	—	—
	—	—	—	3000	10239	10.8
S06	1000	3413	8.3	—	—	—
	—	—	—	—	—	—
	2000	6826	16.7	2000	6828	7.2
	—	—	—	—	—	—
	—	—	—	3000	10239	10.8
	—	—	—	—	—	—
	—	—	—	—	—	—
S08	1000	3413	8.3	2000	6828	7.2
	—	—	—	—	—	—
	2000	6826	16.7	3000	10239	10.8
	—	—	—	—	—	—
	—	—	—	—	—	—
	—	—	—	6000	20748	21.6
	—	—	—	—	—	—
S10	2000	6826	16.7	3000	10239	10.8
	—	—	—	6000	20748	21.6
	—	—	—	8000	27304	28.8
	—	—	—	—	—	—
S12	2000	6826	16.7	3000	10239	10.8
	—	—	—	6000	20748	21.6
	—	—	—	8000	27304	28.8
	—	—	—	—	—	—

\*Electric heat voltage must match motor voltage.

# Dimensional data (inches)

## Model KZZ (Knock-down Unit) Unit Sizes S03 Thru S08 (300 thru 800 cfm)

### Recommended Riser Hole Size in Floor (inches)

RISER	3/4	1	1-1/4	1-1/2	2	2-1/2	3
A	3-1/2	4	4	4-1/2	5	5-1/2	6
(TWO PIPE) B	13-1/2	14	14	14-1/2	15	15-1/2	16
(FOUR PIPE) B	17	17-1/2	17-1/2	18	18-1/2	19	19-1/2

ALL DIMENSIONS APPROXIMATE.  
CERTIFIED DRAWINGS  
AVAILABLE UPON REQUEST.

### NEUTRAL HAND UNIT SHOWN.

Hand of unit determined by facing return air opening.  
Risers on right = Right hand of unit.  
Risers on left = Left hand of unit.  
Risers on back = Neutral unit.

### Thermostat Box Detail

Mud ring can be mounted vertically or horizontally. Opening is 2" x 4"

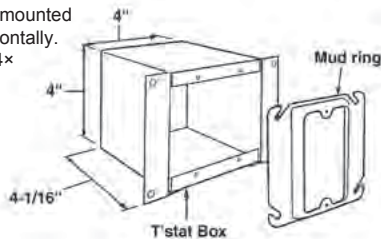

### Recommended Hole in Floor (A x B) (Side and Back Risers) (2)

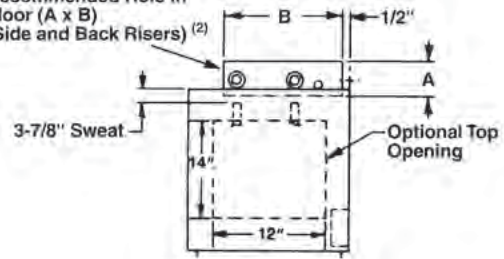

### PLAN VIEW

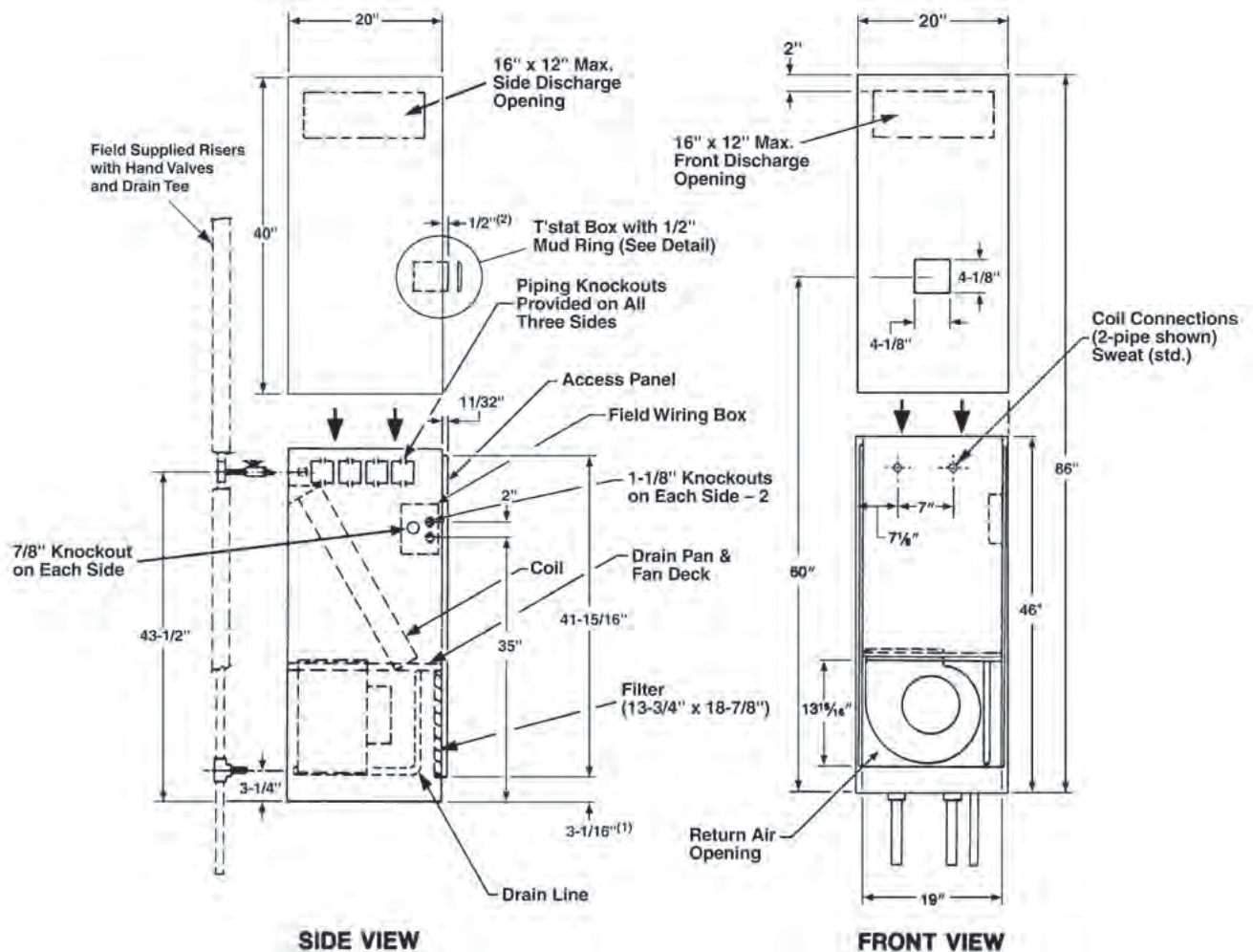

### SIDE VIEW

### FRONT VIEW

### NOTES:

- (1) With return air grille mounted on unit, dimension becomes 23 7/8".
- (2) Fire Stop: If required, must be provided by contractor.

FIELD RISER LOCATION AND DISCHARGE OPENINGS: SEE PAGE 19 FOR DETAIL.

# Dimensional data (inches)

## Model HSS (Basic Unit) Unit Sizes S03 Thru S08 (300 thru 800 cfm)

### Recommended Riser Hole Size in Floor (inches)

RISER	3/4	1	1-1/4	1-1/2	2	2-1/2	3
A	3-1/2	4	4	4-1/2	5	5-1/2	6
(TWO PIPE) B	13-1/2	14	14	14-1/2	15	15-1/2	16
(FOUR PIPE) B	17	17-1/2	17-1/2	18	18-1/2	19	19-1/2

ALL DIMENSIONS APPROXIMATE.  
CERTIFIED DRAWINGS  
AVAILABLE UPON REQUEST.

### NEUTRAL HAND UNIT SHOWN.

Hand of unit determined by facing return air opening.  
Risers on right = Right hand of unit.  
Risers on left = Left hand of unit.  
Risers on back = Neutral unit.

### Thermostat Box Detail

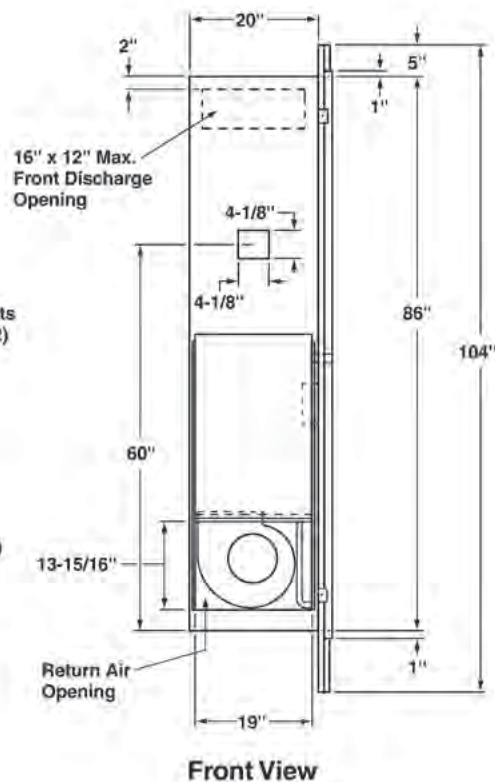
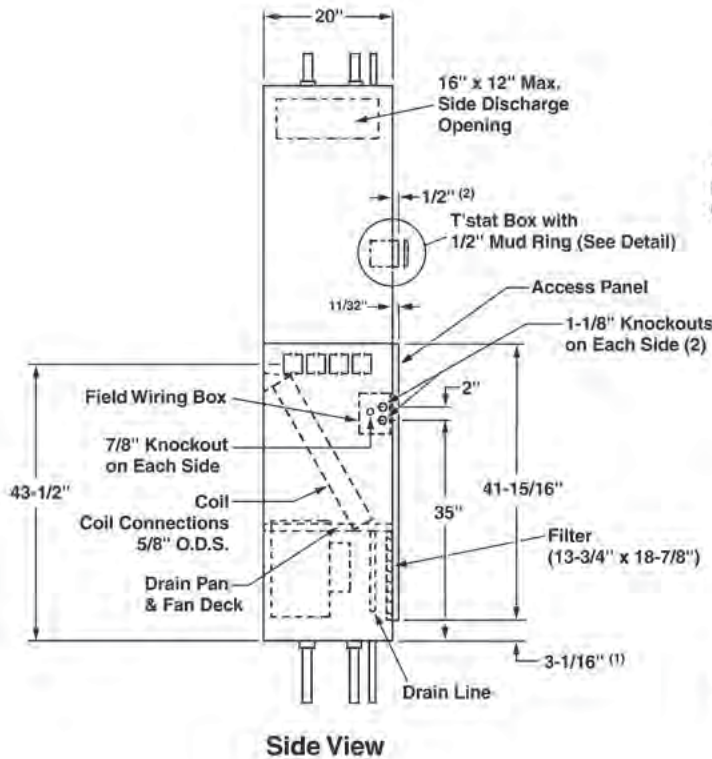
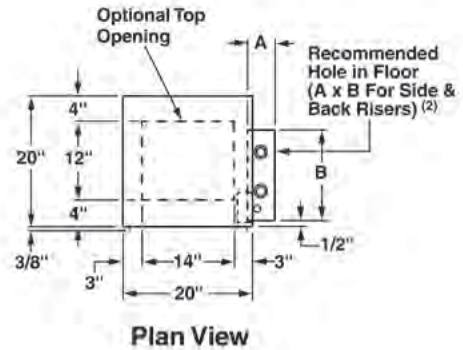
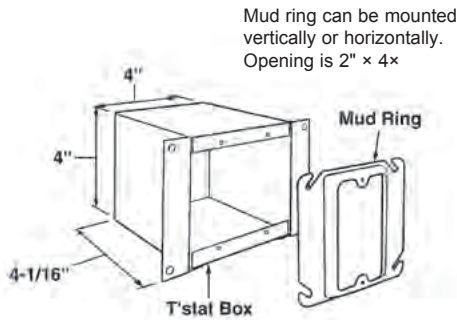

### NOTES:

- (1) With return air grille mounted on unit, dimension becomes 23/8".
- (2) Fire Stop: If required, must be provided by contractor.

FIELD RISER LOCATION AND DISCHARGE OPENINGS: SEE PAGE 19 FOR DETAIL.



# Dimensional data (inches)

## Model HSS (Basic Unit) Unit Sizes S10 Thru S12 (1000 thru 1200 cfm)

### Recommended Riser Hole Size in Floor (inches)

RISER	3/4	1	1-1/4	1-1/2	2	2-1/2	3
A	3-1/2	4	4	4-1/2	5	5-1/2	6
(TWO PIPE) B	13-1/2	14	14	14-1/2	15	15-1/2	16
(FOUR PIPE) B	17	17-1/2	17-1/2	18	18-1/2	19	19-1/2

ALL DIMENSIONS APPROXIMATE.  
CERTIFIED DRAWINGS  
AVAILABLE UPON REQUEST.

### NEUTRAL HAND UNIT SHOWN.

Hand of unit determined by facing return air opening.  
Risers on right = Right hand of unit.  
Risers on left = Left hand of unit.  
Risers on back = Neutral unit.

### Thermostat Box Detail

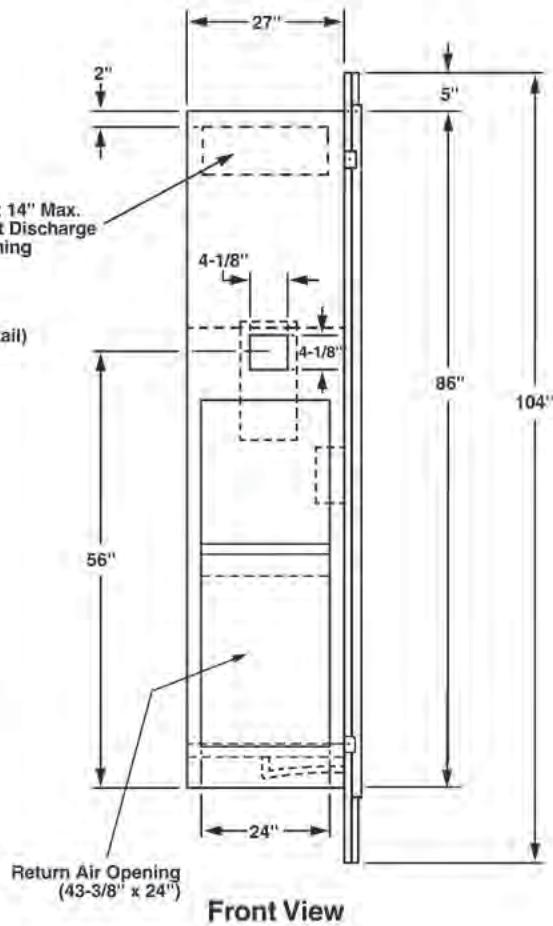
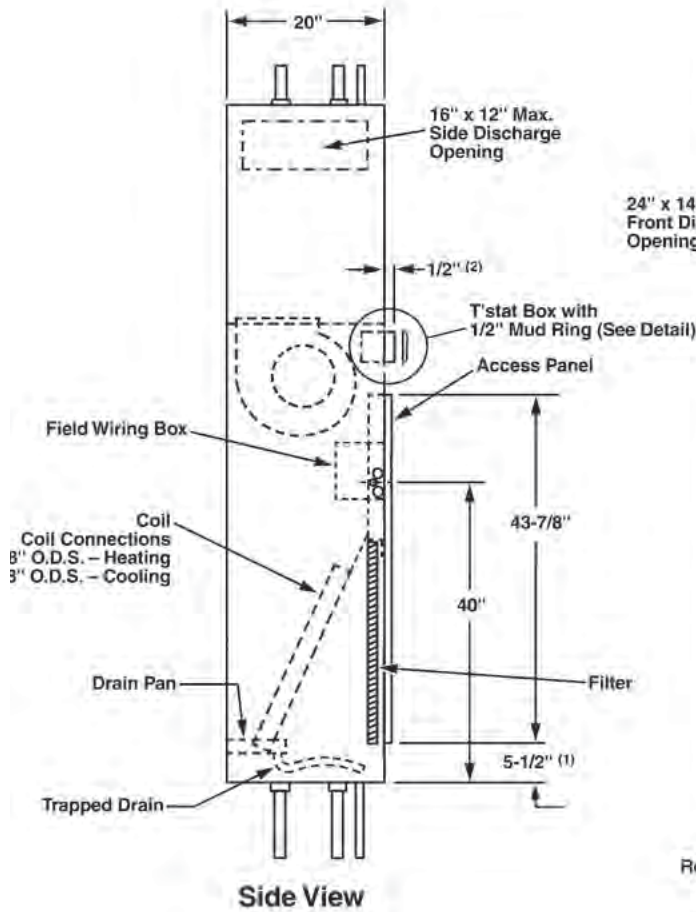
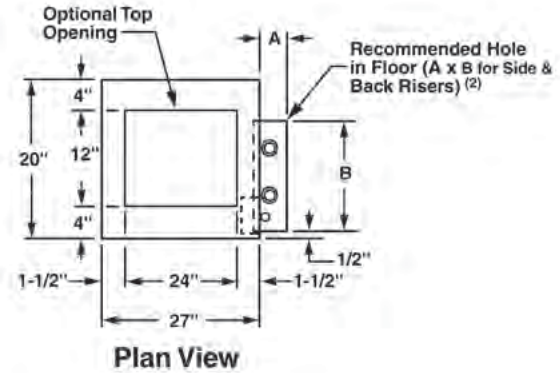
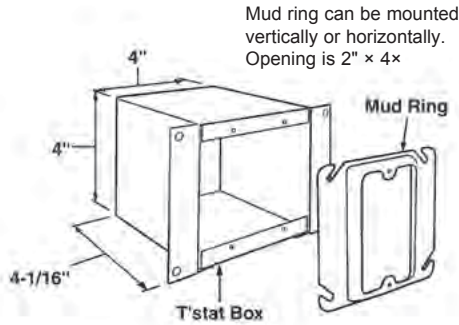

### NOTES:

- (1) With return air grille mounted on unit, dimension becomes 23/8".
- (2) Fire Stop: If required, must be provided by contractor.

FIELD RISER LOCATION AND DISCHARGE OPENINGS: SEE PAGE 21 FOR DETAIL.

## Riser Location — HSS Unit Sizes S10 and S12 (1000 thru 1200 cfm)

**1** **2** **3** **4** REPRESENT AIR DISCHARGE POSITIONS DETERMINED BY FACING RETURN AIR OPENING.

### TWO-PIPE SYSTEM (PLAN VIEW)

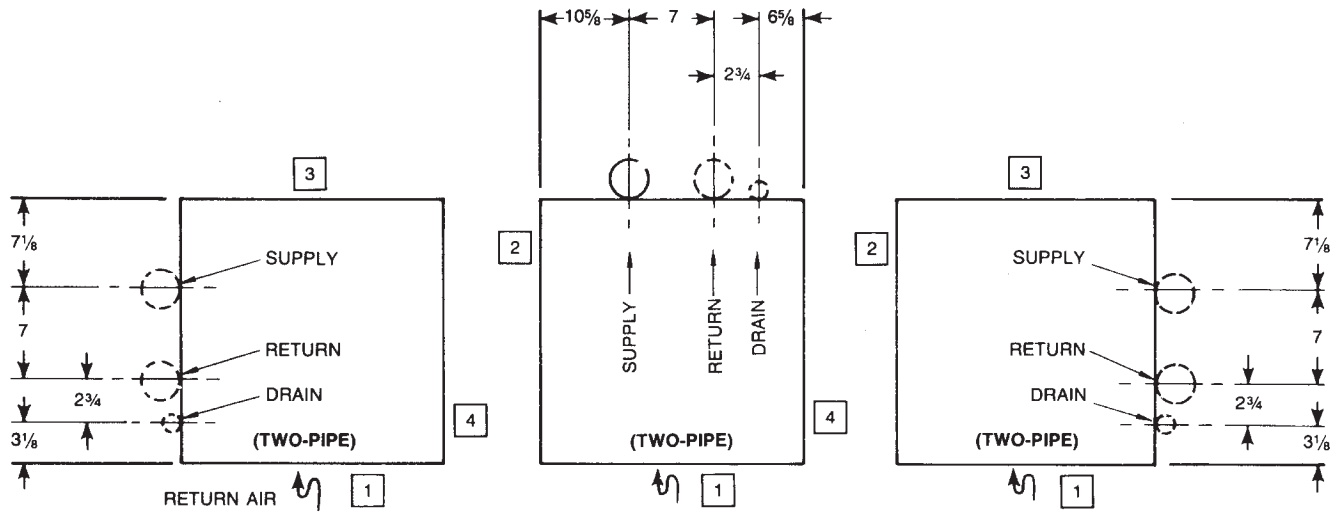

### FOUR-PIPE SYSTEM (PLAN VIEW)

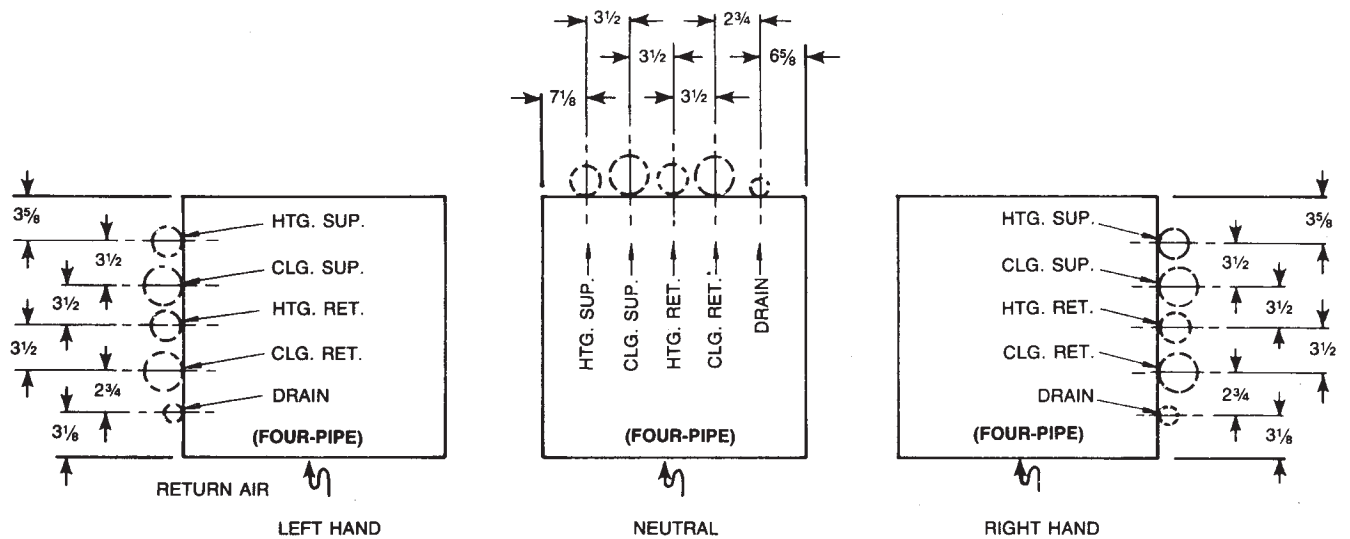

### DISCHARGE OPENINGS

WITH ONE OPENING ONLY, LOCATIONS **1** **3** SHOULD BE 24" x 14"; LOCATIONS **2** **4** SHOULD BE 16" x 14".  
 WITH TWO OR MORE OPENINGS, LOCATIONS **1** **2** SHOULD BE 24" x 8"; LOCATIONS **3** **4** SHOULD BE 16" x 12".

# Riser Location for Master-Slave Units

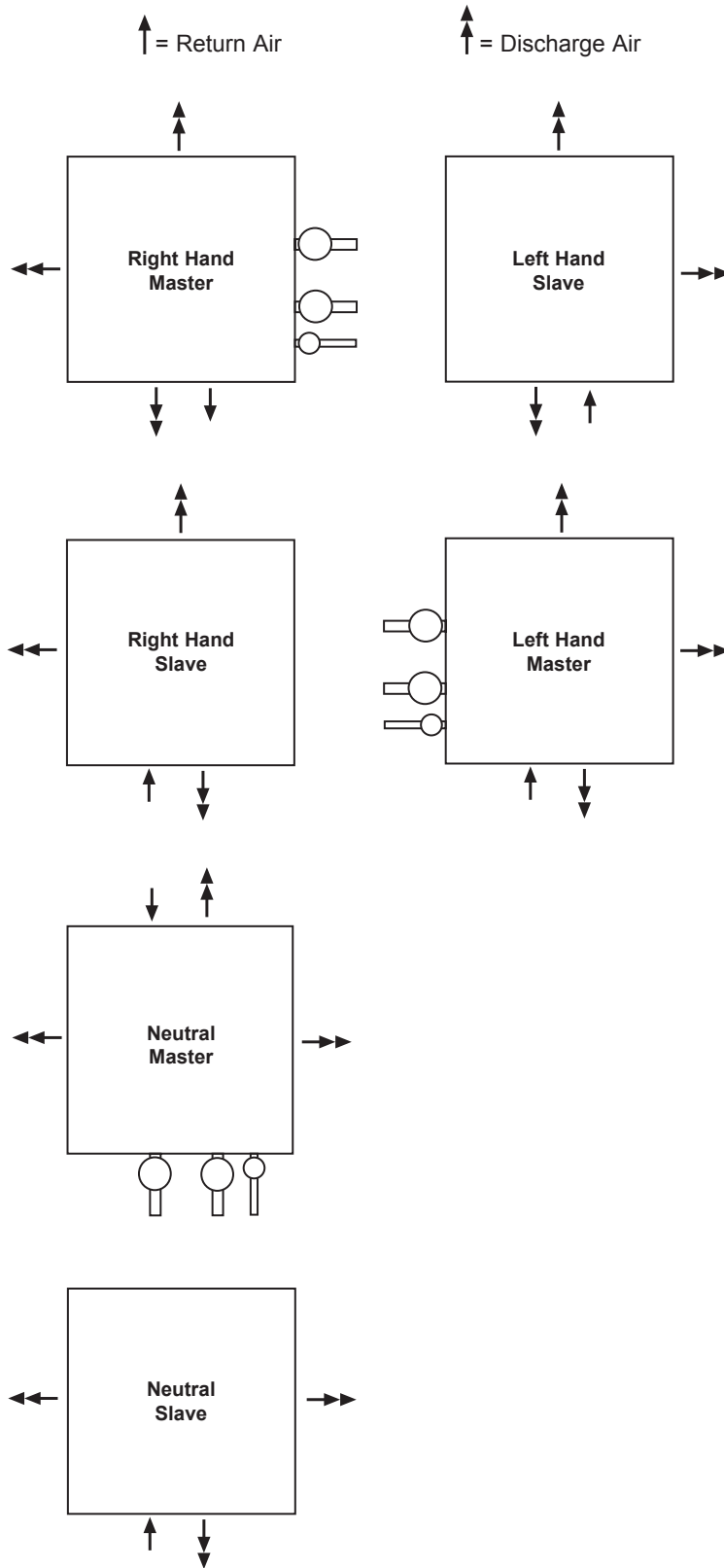

Master units ship with risers attached to the unit. These risers have 3" stub-out's to match with our slave unit piping.

Slave units do not have ball valves attached to the valve package. Ball valves must be purchased separately for field installation (see IM 283-8).

# Typical Fan Cycle Control System Wiring Diagrams

Figure 5.

## 2-Pipe

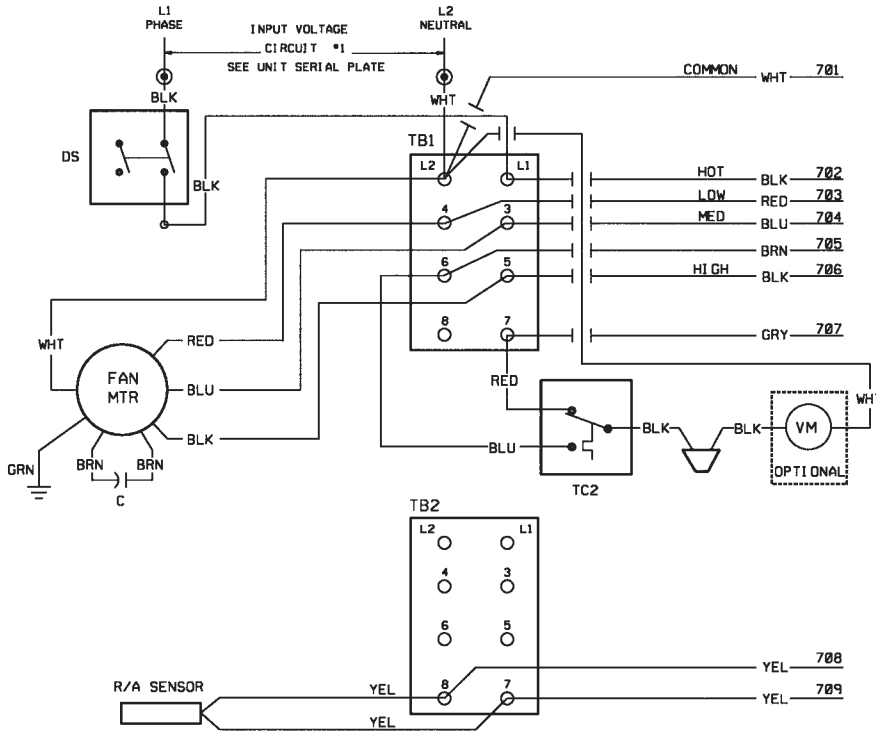

### LEGEND

- REFERENCE
- COMPONENT OUTLINE
- FIELD WIRING
- FACTORY WIRING
- 702 WIRE NO
- BLK WIRE COLOR
- WIRE CONNECTOR
- WIRE CONNECTOR
- FIELD CONNECTOR
- CLG COOLING
- HTG HEATING
- C CAPACITOR
- MTR MOTOR
- R1 RELAY
- VM VALVE
- TC2 CHANGE OVER SWITCH (AUTO)
- DS DISCONNECT SW

Figure 6.

## 4-Pipe

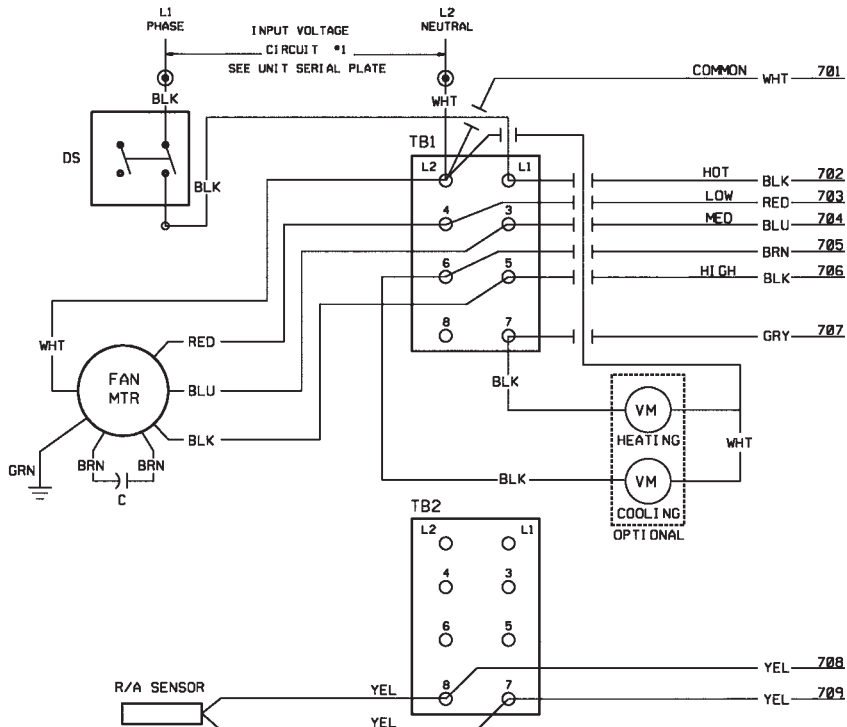
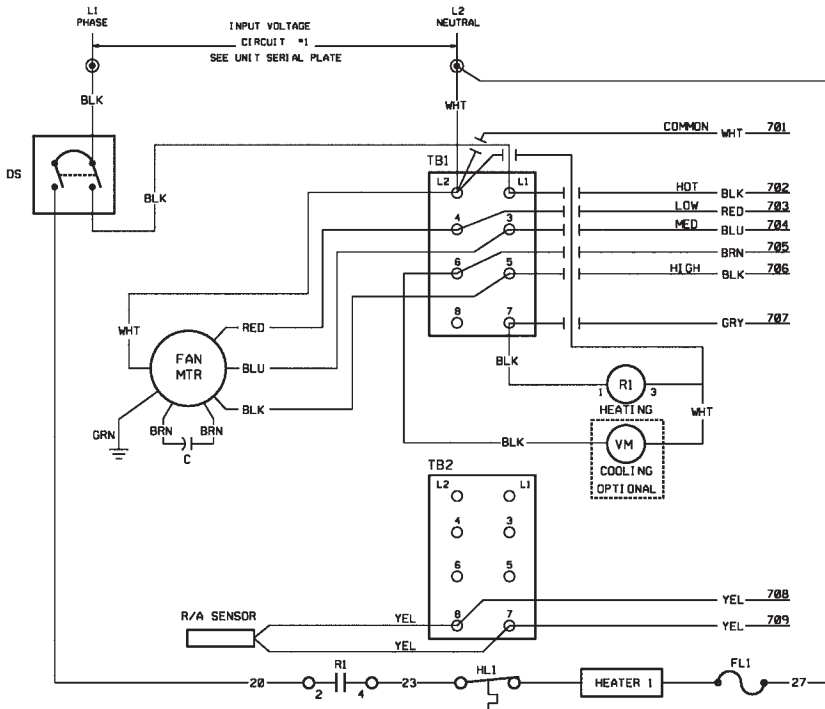

Figure 7.

**2-Pipe with 1Circuit Electric Heat**



**LEGEND**

- REFERENCE
- COMPONENT OUTLINE
- FIELD WIRING
- FACTORY WIRING
- 702 WIRE NO
- BLK WIRE COLOR
- WIRE CONNECTOR
- WIRE CONNECTOR
- FIELD CONNECTOR
- CLG COOLING
- HTG HEATING
- C CAPACITOR
- MTR MOTOR
- R1 RELAY
- VM VALVE
- TC2 CHANGE OVER SWITCH (AUTO)
- DS DISCONNECT SW

Figure 8.

**4-Pipe with 2Circuit Electric Heat**

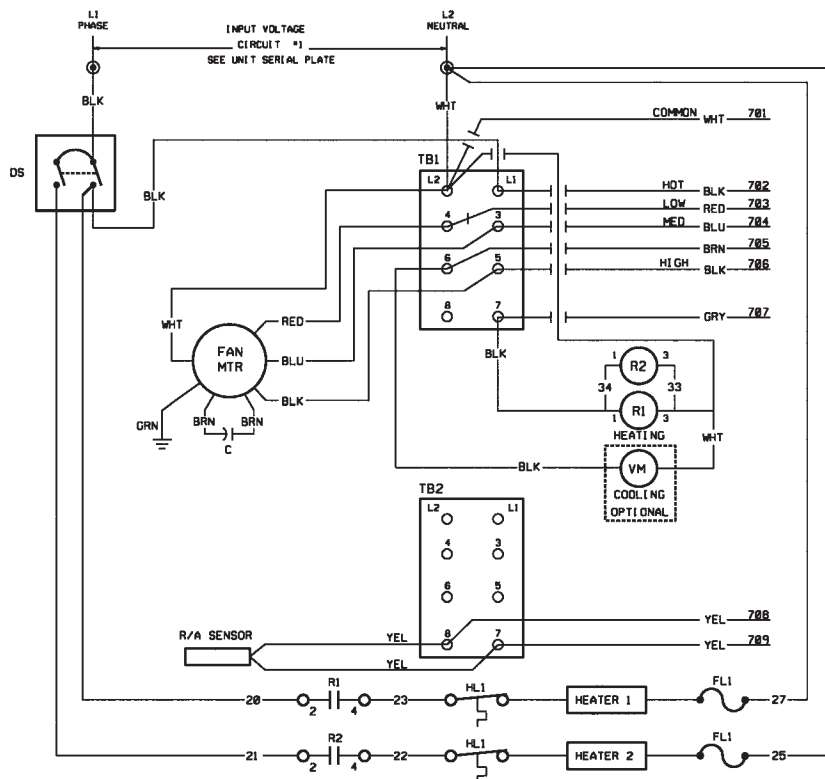

# Engineering guide specifications

## Model HSS (Basic Unit) Unit Sizes S03 thru S08 (300 thru 800 cfm)

Furnish and install where shown on plans McQuay low cfm design HiLine – units. Unit sizes, performance and equipment shall be as tabulated in the schedule. Unit performance shall be substantiated by computer generated output data.

**UNIT CONFIGURATION** – Unit shall be (two-pipe)(four-pipe) system blow-through configuration with completely removable chassis. Filter, fan assembly, drain line and motor shall be accessible by removing the return air grille panel. Internal controls, service valves, drain pan and coil shall be accessible by removing the access and sound baffle panel. Hand of unit shall be tabulated in the schedule.

**CABINET** – Cabinet shall be fabricated of heavy-gauge galvanized steel and fully insulated with 1/2" multi-density glass fiber. An insulated galvanized steel access and sound baffle panel shall completely enclose the coil section. The return air grille panel shall be heavy-gauge steel with a stamped (bar type) grille and electrostatically applied baked semi-gloss finish and extend 5/8" in front of unit face.

**PLASTER FRAME** – A plaster frame shall be provided to hold the return air grille panel away from the wall when the unit is furred in. A snap-on return air grille panel shall be provided with the plaster frame.

**COILS** – Units shall be ARI certified with standard low flow heating/cooling coils in two-pipe systems, or, standard low flow cooling coil plus one-row heating coil in four-pipe systems. All coils shall be seamless copper tubes in a staggered pattern with rippled and corrugated aluminum fins. Tubes shall be mechanically expanded into the fin collars for positive fin-to-tube bond. Coils shall have manual air vents. Internal piping shall allow for vertical riser expansion of  $\pm 1"$ . Coil performance shall be as tabulated in the schedule. Coil shall be positioned to provide positive condensate drainage.

**FAN ASSEMBLY** – Unit sizes S03 and S04: Fan housings shall be two-piece with integral scroll and inlets. Fan wheels shall be DWDI forward curved centrifugal direct drive type.

Unit sizes S06 and S08: Fan housings shall be painted steel with integral scroll and separate inlets. Fan wheels shall be painted steel DWDI forward curved centrifugal direct type.

All fan wheels shall be statically and dynamically balanced.

**MOTORS** – Motors shall be permanent split capacitor type (115/60/1) (277/60/1) with sleeve bearings, oilers, inherent thermal overload protection with automatic reset and resilient mounts.

**DRAIN PAN** – Drain pan shall be galvanized steel with drain line and closed cell insulation on the external surface to prevent condensation.

**SUPPLY & RETURN RISERS** – Supply and return risers shall be type "L" copper (optional copper types and diameters shall be as tabulated in the schedule), with 3/4" closed cell flexible foam insulation, factory installed ball valves on risers. Slip couplings shall be factory available for field connection. Insulation shall meet or exceed current flammability classification UL94.

**DRAIN RISER** – Drain riser shall be PVC. (Optional copper types and diameters shall be as tabulated in the schedule). Stop type couplings shall be factory available for field connection.

**CONTROL SYSTEMS** – A variety of thermostats, unit or wall mounted, shall be offered to control all different options for fan and valve cycling. For unit mounted thermostats all wiring shall be provided to the control box for easy field installation (optional Molex connections shall be available upon request). A 10K thermistor shall be mounted in all units. The 10K thermistor shall be used for factory provided thermostats or for field provided controls. The thermostat electrical box shall be adjustable for any wall thickness up to 3-7/8" and a 1/2" mud ring shall be provided (an optional 5/8" mud ring shall be provided upon request).

**FILTERS** – Filters shall be nominal 1" thick throwaway.

**DISCHARGE GRILLES (OPTIONAL)** – Optional aluminum (single deflection) (double deflection) discharge grilles shall be provided in sizes and positions as tabulated in the schedule.

**LINE-OF-SIGHT BAFFLE (OPTIONAL)** – An optional line-of-sight baffle shall be supplied as tabulated in the schedule.

**FRESH AIR DAMPERS (OPTIONAL)** – Two-position (motorized)(manual) fresh air damper shall be factory available as tabulated in the schedule.

**ELECTRIC HEAT (OPTIONAL)** – Electric heating elements and controls shall be completely installed, wired and enclosed at the factory. Heating element shall be fully protected by a high limit cut-out with automatic reset.

**OPTIONAL CONTROLS & VALVES** – Valve cycle control systems for two-pipe and four-pipe systems, two-way or three-way motorized valves and other combinations of ball valves and automatic flow metering devices shall be installed as tabulated in the schedule.

**TWIN UNITS (OPTIONAL)** – Twin unit configuration, as tabulated, shall be such that two adjacent room units will be piped to a single set of risers and will operate with separate controls on each unit.

## Unit Sizes S10 & S12 (1000 thru 1200 cfm)

Furnish and install where shown on plans McQuay high cfm design HiLine Fan Coil units. Unit sizes, performance and equipment shall be as tabulated in the schedule. Unit performance shall be substantiated by computer generated output data.

**UNIT CONFIGURATION** – Unit shall be (two-pipe)(four-pipe) system draw-through configuration. Filter, drain line and drain pan shall be accessible by removing the return air grille panel. Controls, service valves, coil, motor and fan assembly shall be accessible by removing the inner sound baffle panel. Hand of unit shall be as tabulated in the schedule.

**CABINET** – Cabinet shall be fabricated of heavy-gauge galvanized steel and fully insulated with 1/2" multi-density glass fiber. An insulated galvanized steel access and sound baffle panel shall completely enclose the internal controls and fan assembly section. The return air grille panel shall be heavy-gauge steel with a stamped (bar type) grille and electrostatically applied baked semi-gloss finish and extend 5/8" in front of unit face.

**PLASTER FRAME** – A plaster frame shall be provided to hold the return air grille panel away from the wall when the unit is furred in. A snap-on return air grille panel shall be provided with the plaster frame.

**COILS** – Units shall be ARI certified with standard low flow heating/cooling coils in two-pipe systems, or, standard low flow cooling coil plus one-row heating coil in four-pipe systems. All coils shall be seamless copper tubes in a staggered pattern with rippled and corrugated aluminum fins. Tubes shall be mechanically expanded into the fin collars for positive fin-to-tube bond. Coils shall have manual air vents and ball valves on the supply and return lines. Internal piping shall allow for vertical riser expansion of  $\pm 1"$ . Coil performance shall be as tabulated in the schedule. Coil shall be positioned to provide positive condensate drainage.

**FAN ASSEMBLY** – Fans shall be DWDI forward curved centrifugal, direct drive type and statically and dynamically balanced. Fan housings shall be painted steel with integral scroll and inlets.

**MOTORS** – Motors shall be permanent split capacitor type (115/60/1) (265/277/60/1) with sleeve bearings, oilers, inherent thermal overload protection with automatic reset and resilient mounts.

**DRAIN PAN** – Drain pan shall be galvanized steel and easily accessible.

**SUPPLY & RETURN RISERS** – Supply and return risers shall be type "L" copper (optional copper types and diameters shall be as tabulated in the schedule), with 3/4" closed cell flexible foam insulation factory installed. Non-stop slip couplings shall be factory available for field connection. Insulation shall meet or exceed current flammability classification UL94.

**DRAIN RISERS** – Drain risers shall be PVC (optional copper types and diameters shall be as tabulated in the schedule). Couplings shall be factory available for field connection.

**CONTROL SYSTEMS** – A variety of thermostats, unit or wall mounted, shall be offered to control all different options for fan and valve cycling. For unit mounted thermostats all wiring shall be provided to the control box for easy field installation (optional Molex connections shall be available upon request). A 10K thermistor shall be mounted in all units. The 10K thermistor shall be used for factory provided thermostats or for field provided controls. The thermostat electrical box shall be adjustable for any wall thickness up to 3-7/8" and a 1/2" mud ring shall be provided (an optional 5/8" mud ring shall be provided upon request).

**FILTERS** – Filters shall be nominal one-inch thick throwaway.

**DISCHARGE GRILLES (OPTIONAL)** – Optional aluminum (single deflection) (double deflection) discharge grilles shall be provided in sizes and positions as tabulated in the schedule.

**LINE-OF-SIGHT BAFFLE (OPTIONAL)** – An optional line-of-sight baffle shall be supplied as tabulated in the schedule.

**ELECTRIC HEAT (OPTIONAL)** – Electric heating elements and controls shall be completely installed, wired and enclosed at the factory. Heating element shall be fully protected by a high limit cut-out with automatic reset.

**OPTIONAL CONTROLS & VALVES** – Valve cycle control systems for two-pipe and four-pipe systems, two-way or three-way motorized valves and other combinations of ball valves and automatic flow metering devices shall be installed as tabulated in the schedule.

**TWIN UNITS (OPTIONAL)** – Twin unit configuration, opposite hand only, as tabulated, shall be such that two adjacent room units will be piped to a single set of risers and will operate with separate controls on each unit.

## Model KZZ (Knock-down Unit) Unit Sizes S03 Thru S08 (300 Thru 800 cfm)

Furnish and install where shown on plans McQuay knock-down HiLine Fan Coil units. Unit sizes, performance and equipment shall be as tabulated in the schedule. Unit performance shall be substantiated by computer generated output data.

**UNIT CONFIGURATION** – Unit shall be (two-pipe)(four-pipe) system blow-through configuration with completely removable chassis. Filter, fan assembly, drain line and motor shall be accessible by removing the return air grille panel. Internal controls, service valves, drain pan and coil shall be accessible by removing the access and sound baffle panel. Hand of unit shall be as tabulated in the schedule.

**CABINET** – Cabinet shall be fabricated of heavy-gauge galvanized steel and fully insulated with 1/2" multi-density glass fiber. An insulated galvanized steel access and sound baffle panel shall completely enclose the coil section. The return air grille panel shall be heavy-gauge steel with a stamped (bar type) grille and electrostatically applied baked semi-gloss finish and extend 5/8" in front of unit face.

**PLASTER FRAME** – A plaster frame shall be provided to hold the return air grille panel away from the wall when the unit is furred in. A snap-on return air grille panel shall be provided with the plaster frame.

**COILS** – Units shall be ARI certified with standard low flow heating/cooling coils in two-pipe systems, or, standard low flow cooling coil plus one-row heating coil in four-pipe systems. All coils shall be seamless copper tubes in a staggered pattern with rippled and corrugated aluminum fins. Tubes shall be mechanically expanded into the fin collars for positive fin-to-tube bond. Coils shall have manual air vents. Internal piping shall allow for vertical riser expansion of  $\pm 1"$ . Coil performance shall be as tabulated in the schedule. Coil shall be positioned to provide positive condensate drainage.

**FAN ASSEMBLY** – Unit sizes S03 and S08: Fan housings shall be two-piece with integral scroll and inlets. Fan wheels shall be DWDI forward curved centrifugal direct drive type.

Unit sizes S06 and S08: Fan housings shall be painted steel with integral scroll and separate inlets. Fan wheels shall be painted steel DWDI forward curved centrifugal direct type.

All fan wheels shall be statically and dynamically balanced.

**MOTORS** – Motors shall be permanent split capacitor type (115/60/1)

(277/60/1) with sleeve bearings, oilers, inherent thermal overload protection with automatic reset and resilient mounts.

**DRAIN PAN** – Drain pan shall be galvanized steel with drain line and closed cell insulation on the external surface to prevent condensation.

**SUPPLY & RETURN RISERS** – Supply and return risers are to be (field supplied)(factory supplied) and field installed. Risers can be installed prior to unit placement.

**DRAIN RISER** – Drain risers are to be (field supplied)(factory supplied) and field installed. Risers can be installed prior to unit placement.

**CONTROL SYSTEMS** – A variety of thermostats, unit or wall mounted, shall be offered to control all different options for fan and valve cycling. For unit mounted thermostats all wiring shall be provided to the control box for easy field installation (optional Molex connections shall be available upon request). A 10K thermistor shall be mounted in all units. The 10K thermistor shall be used for factory provided thermostats or for field provided controls. The thermostat electrical box shall be adjustable for any wall thickness up to 3-7/8" and a 1/2" mud ring shall be provided (an optional 5/8" mud ring shall be provided upon request).

**FILTERS** – Filters shall be nominal one-inch thick throwaway.

**DISCHARGE GRILLES (OPTIONAL)** – Optional aluminum (single deflection) (double deflection) discharge grilles shall be provided in sizes and positions as tabulated in the schedule.

**LINE-OF-SIGHT BAFFLE (OPTIONAL)** – An optional line-of-sight baffle shall be supplied as tabulated in the schedule.

**FRESH AIR DAMPERS (OPTIONAL)** – Two position (motorized)(manual) fresh air damper shall be factory available as tabulated in the schedule.

**ELECTRIC HEAT (OPTIONAL)** – Electric heating elements and controls shall be completely installed, wired and enclosed at the factory. Heating element shall be fully protected by a high limit cut-out with automatic reset.

**OPTIONAL CONTROLS & VALVES** – Valve cycle control systems for two-pipe and four-pipe systems, two-way or three-way motorized valves and other combinations of ball valves and automatic flow metering devices shall be installed as tabulated in the schedule.

**TWIN UNITS (OPTIONAL)** – Twin unit configuration, opposite hand only, as tabulated, shall be such that two adjacent room units will be piped to a single set of risers and will operate with separate controls on each unit.

# Total system capability.

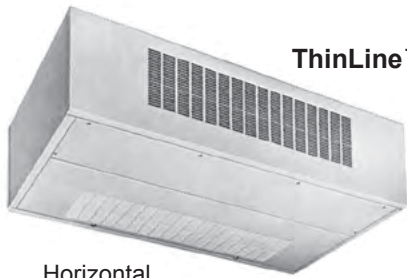

Horizontal

ThinLine™ Fan-coils

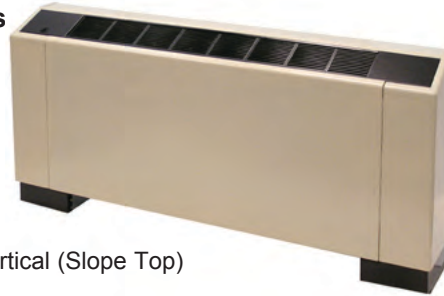

Vertical (Slope Top)

HiLine™ Fan-coil



Large Capacity Fan-coils



Cabinet

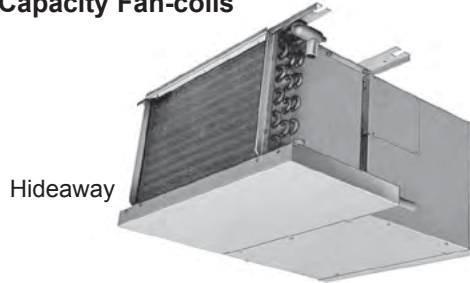

Hideaway

Unit Heaters



Vertical Unit Heater



Horizontal Unit Heater

## *McQuay Training and Development*

Now that you have made an investment in modern, efficient McQuay equipment, its care should be a high priority. For training information on all McQuay HVAC products, please visit us at [www.mcquay.com](http://www.mcquay.com) and click on training, or call 540-248-9646 and ask for the Training Department.

## *Warranty*

All McQuay equipment is sold pursuant to its standard terms and conditions of sale, including Limited Product Warranty. Consult your local McQuay Representative for warranty details. Refer to Form 933-43285Y. To find your local McQuay Representative, go to [www.mcquay.com](http://www.mcquay.com).

This document contains the most current product information as of this printing. For the most up-to-date product information, please go to [www.mcquay.com](http://www.mcquay.com).

Products manufactured in an ISO certified facility.

